

GSD INDUSTRIAL CO., LTD.

CSS

沉水式不锈钢污物(泥)泵



川源股份有限公司



用途

1. 畜牧养殖；
2. 食品加工及餐饮业；
3. 造纸、制革业；
4. 各式废水处理。

特点

1. 本产品采用不锈钢及工程塑胶为材质，重量轻；
2. 适用液体温度：0~40°C；
3. 机械轴封：双机械密封，轴封材质为碳化硅；
4. 马达：鼠笼式感应电动机，并符合 IP68；
5. 通过污物直径：0.5 倍的出口口径；
通过污物长度：3 倍的出口口径。

标准配备

1. 防水电缆 5 米；
2. 衔接凸缘：PP 制一个；
3. 附出口排气阀；
4. 过热保护器；

选择配备

1. 自动着脱装置
使泵浦安装保养修护迅速容易，毋须先清除桶槽污水；
2. 控制盘及浮球开关(3 相)
使泵浦可以交替并列操作；
3. 单相使用浮球开关；
4. 不锈钢材质，可依客户需求采用 SUS316。

APPLICATIONS

1. Livestock industry.
2. Food stuff processing factory.
3. Leather process industry.
4. Other waste water treatment works.

FEATURES

1. Product material of stainless steel and industrial plastic, light in weight.
2. Liquid temperature : 0~40°C.
3. Mechanical seal: Double Mechanical seals material using for seal ring and floating seat is Silicon Carbide.
4. Motor: Squirrel Cage Induction Motor, Fclass insulation, IP68.
5. Diameter of wastes: 1/2 times of discharge diameter.
Length of wastes: three times of discharge diameter.

STANDARD ACCESSORIES

1. Waterproof cable is 5m length.
2. Companion flange is made of PP
3. With outlet vent valve.
4. Thermostat.

OPTIONAL ACCESSORIES

1. AUTO-SETTER
- to allow pump for easy installation, maintenance, and repair, as it is no need to empty tank first.
2. CONTROL PANEL & FLOAT SWITCH
- to allow automatic pump operations, enabling alternating and parallel operations also.
3. Single phase operated float switch.
4. Stainless steel made parts of pump may choose the use of SUS316, according to the customer's need.

型号说明

TYPE DESCRIPTION

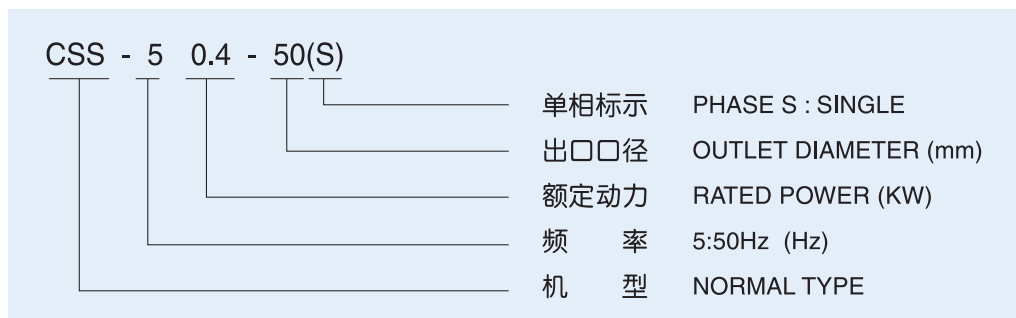

结构图 CONSTRUCTION

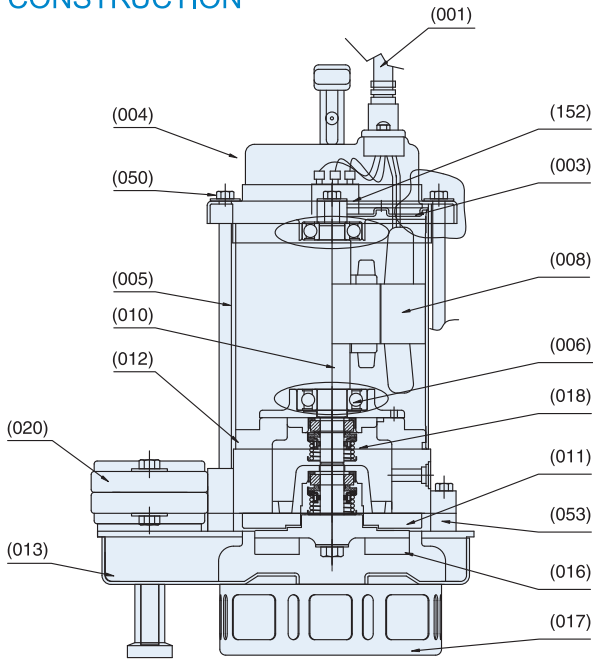

NO.	名称	NAME	材质 MATERIAL
001	电缆	CABLE	VCT
003	轴承座	BEARING COVER	SUS 304
004	马达盖	MOTOR COVER	SUS 304
005	马达本体	MOTOR CASING	SUS 304
006	轴承	BEARING	NSK(or SKF)
008	定子	STATOR	F CLASS
010	主轴	SHAFT	SUS 410
011	油箱盖	OIL COVER	PP
012	中承座	BRACKET	PP
013	泵浦本体	PUMP CASING	PP+SUS 304
016	叶轮	IMPELLER	PP/FC200
017	滤底座	STRAINER	SUS 304
018	机械轴封	MECH. SEAL	CARBON/SILICON
020	凸缘	FLANGE	PP
050	螺杆	BOLT	SUS 304
053	垫片	WASHER	FC200
152	温度开关	THERMOSTAT	—

性能表 SPECIFICATIONS

型号 TYPE	电机 MOTOR					泵浦 PUMP				重量 WEIGHT KG
	功率		相数	极数	频率	口径 DISCH.DIA		扬程 HEAD	流量 CAP.	
	KW	HP	Phase	Pole	Hz	mm	in	M	L/min	
CSS-50.4-50(S)	0.4	0.5	3(1)	2	50	50	2"	5	130	10.5
CSS-50.75-50(S)	0.75	1	3(1)	2	50	50	2"	6	220	12
CSS-51.5-80	1.5	2	3	2	50	80	3"	8	350	17
CSS-52.2-80	2.2	3	3	2	50	80	3"	10	400	19

性能曲线 PERFORMANCE CURVE

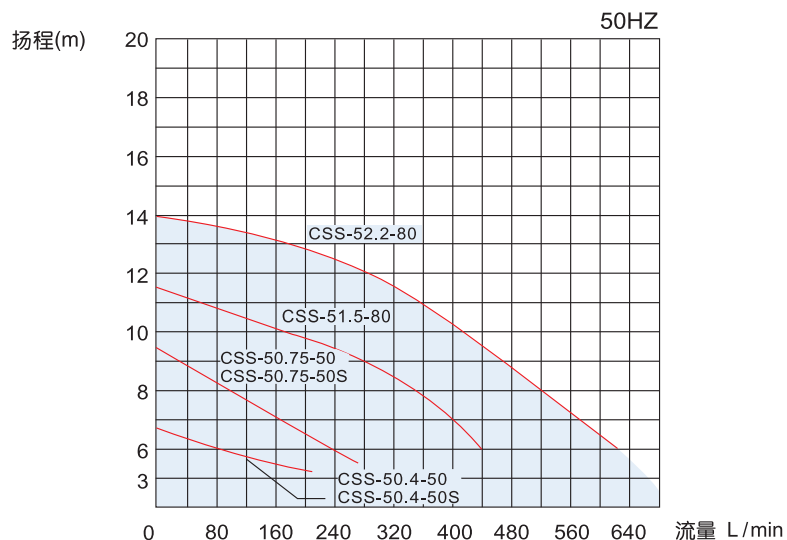

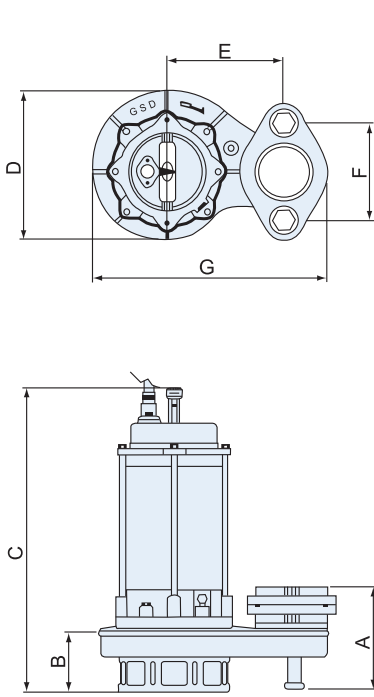

FIG. 1

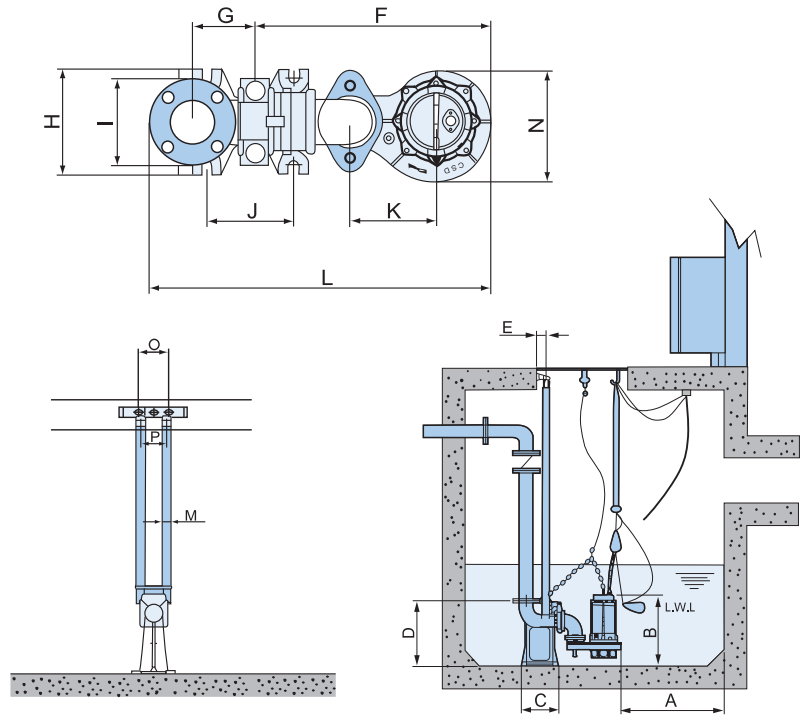

FIG. 2

无着脱式外形尺寸 (FIG. 1)
DIMENSIONS (WITHOUT AUTOSETTER)

(mm)

型号 TYPE	A	B	C	D	E	F	G	型号 TYPE	A	B	C	D	E	F	G
CSS-50.4-50	138	85	410	190	122	98	257	CSS-50.75-50S	138	85	470	190	122	98	257
CSS-50.4-50S	138	85	410	190	122	98	257	CSS-51.5-80	163	100	466	230	180	150	362
CSS-50.75-50	138	85	430	190	122	98	257	CSS-52.2-80	163	100	486	230	180	150	362

附着脱式外形尺寸 (FIG. 2)
DIMENSIONS (WITH AUTOSETTER)

(mm)

型号 TYPE	A	B	C	D	E	F	G	H	I	J	K	L	M	N	O	P
CSS-□□-50	>1500	370	180	310	59	318	130	150	120	110	122	518	25A	190	140	135
CSS-□□-80	>1500	440	226	434	59	458	163	220	180	180	180	713	25A	230	140	135

