

CNP 南方泵业



NISO, NIS, NISF

50Hz

端吸离心泵



股票代码：300145

南方泵业股份有限公司

NANFANG PUMP INDUSTRY CO.,LTD.

公司地址：中国·杭州

服务热线：400-826-7722

电子邮箱：service@nanfang-pump.com

网址 (WEB)：www.cnppump.com

140609

数据仅供参考：如有修改，恕不通知。

版权所有，盗版必究！

南方泵业股份有限公司

NANFANG PUMP INDUSTRY CO.,LTD.

南方泵业股份有限公司（以下简称南方泵业）创建于1991年，2010年12月9日在深圳交易所发行上市，股票简称：“南方泵业”，股票代码：“300145”。

南方泵业系全国最早研发并规模化生产不锈钢冲压焊接离心泵企业，是目前国内不锈钢冲压焊接离心泵领域产销量最大的专业生产厂家，并在湖南设立了大泵的生产基地。产品的系列范围、销售总量、产品质量均排在国内同行业首位。也是行业内率先研制、生产、销售管网叠压成套设备的企业。公司建立了完善的营销服务网络，在不断满足国内市场需求的同时积极出口海外市场，产品广泛应用于增压、工业、生活供水、空调水循环、供暖、消防系统、地下水抽取、污水废水处理、化工行业和海水淡化等诸多领域。

主导产品有：CDL、CDLF系列不锈钢轻型立式多级离心泵；CHL、CHLF、CHLFT系列不锈钢轻型卧式多级离心泵；DRL恒压变频供水设备，NFWG无负压变频供水设备。CHLF系列轻型卧式多级离心泵，CHLK系列空调专用泵，WQ系列污水污物潜水电泵，SJ系列不锈钢多级深井潜水电泵，QY系列自吸式气液混合泵，CDLK系列浸入式多级离心泵，TD系列管道循环泵，MS系列轻型不锈钢卧式单级离心泵，NISO、NIS、NISF系列端吸离心泵、ZS系列不锈钢卧式单级离心泵，SWB系列不锈钢卧式单级离心泵，SP系列无堵塞自吸式排污泵，VMHP系列海水淡化高压泵，NSC单级双吸中开式离心泵，NDS卧式中开多级离心泵，VTP立式长轴透平泵等系列产品，性能指标均处于国内领先水平。

如今南方泵业已步入高速发展的轨道，在“打造中国泵业强企和世界泵业知名品牌”的康庄大道上迈出了跨越性的一步。并为更好的满足客户需要和业务拓展需求，在全国建立了广泛的销售与服务网络，在全国各大中城市均设有直属办事处及服务中心，旨在为客户提供最为及时、满意的服务；同时，公司产品已成功进军国际市场，同欧美、东南亚等60多个国家和地区的客户均建立了良好的业务往来关系。

以此为契机，南方泵业秉承“诚信共赢 超越自我”，“竞有道 创无限”的企业理念，充分满足客户和市场需求，为实现“绿色水力专家”而不懈努力！



总体数据

型号含义	3
最小进口压力	3
典型应用	3
泵结构	3
性能参数	3
曲线条件	3
特点	3
型谱图	4
截面图	5
零件材料	5
产品范围	7

技术数据

2极	
50-32-160/50-32-200	11
65-40-200/65-40-250	12
65-40-315/65-50-160	13
80-50-200/80-50-250	14
80-50-315/80-65-160	15
100-65-200/100-65-250	16
100-65-315/100-80-160	17
125-100-200/125-100-250	18
125-100-315	19
4极	
50-32-160	19
50-32-200/65-40-200	20
65-40-250/65-40-315	21
65-50-160/80-50-200	22
80-50-250/80-50-315	23
80-65-160/100-65-200	24
100-65-250/100-65-315	25
100-80-160/125-100-200	26
125-100-250/125-100-315	27
125-80-400/125-100-400	28
150-125-250/150-125-315	29
150-125-400/200-150-315	30
200-150-400/250-200-315	31
250-200-400	32
NISO泵外形尺寸图	33
NISO泵外形尺寸表	34
NISO泵组外形尺寸图	36
NISO泵组外形尺寸表	36
NIS、NISF泵外形尺寸图	41
NIS、NISF泵外形尺寸表	41

型号含义

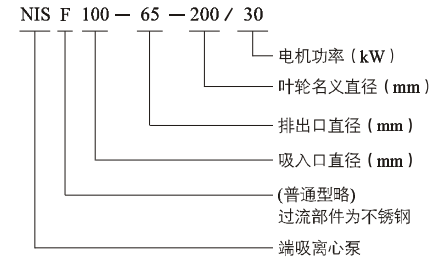
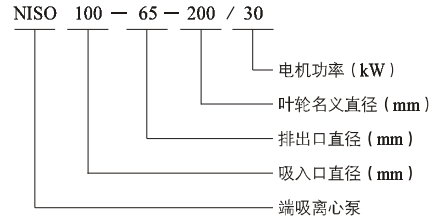

最小进口压力

最小进口压力取决于NPSH值+0.5米的安全余量+汽化压力。如果下列情况发生，重新计算入口压力：

- 液体温度较高
- 液体流速超过了额定值
- 吸程较大或进口管路较长
- 系统压力太小
- 进口条件差、工作压力低

典型应用

● 产品适宜在清洁、稀薄、非侵蚀、非易燃易爆且不含固体颗粒或纤维的液体中使用。

- 供水系统
- 供热、空调系统
- 增压供水、恒压供水
- 消防、喷淋系统
- 灌溉、畜牧使用
- 工业冷却、加热循环系统
- 工业输送、排放系统

泵结构

- 泵为非自吸、单级单吸卧式，轴向往水，径向出水，泵体底部与底座固定。
- 采用标准型耐磨机械密封。
- 全封闭风冷标准电机，尺寸符合IEC标准。
- NISO采用轴承架，可进行轴承定位，避免轴承的轴向窜动，同时提高了转子部件的刚性。
- NISO整体式泵轴，采用油脂润滑的导向深沟球轴承。
- NISO泵与电机之间采用半弹性联轴器相连。
- NISO泵外形及安装尺寸符合ISO 2858标准。
- NIS、NISF泵采用直联型联接加长轴结构。

性能参数

- 最大流量：800m³/h
- 最高扬程：160m
- 最大工作压力：16巴
- 最大进口压力：6巴
- 最大功率：160kW
- 介质温度：-15°C ~ 110°C
- 进出口径：进口口径：DN50 ~ DN250
出口口径：DN32 ~ DN200

曲线条件

- 下列说明适用于后面所示的曲线。
- 曲线容差符合ISO 9906，附录A。
 - 所有曲线都基于电机在恒速2900rpm、2950rpm、1450rpm或1480rpm的测量值。
 - 测试采用20°C不含空气的水，运动粘度为1mm²/s。

特点

- 采用后拉式结构，维修时无须拆除泵体及管路。
- NISO泵型仅采用4种泵轴及悬架体部件，提高了零件的互换性。
- 叶轮进行了优化设计，进口口径加大，无涡流，有效地降低水泵汽蚀余量，使得水泵运行平稳低噪声。
- NIS、NISF泵体积小、结构紧凑、安装简单。

型谱图

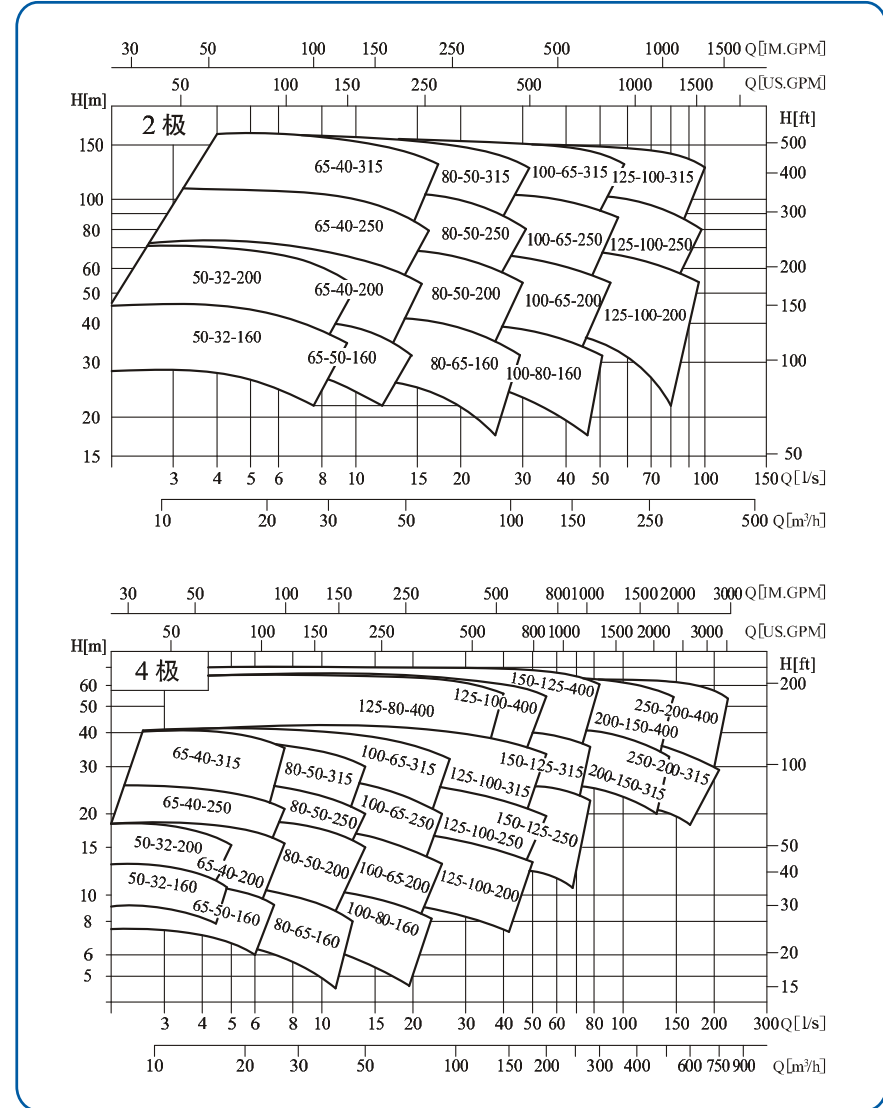

NISO截面图

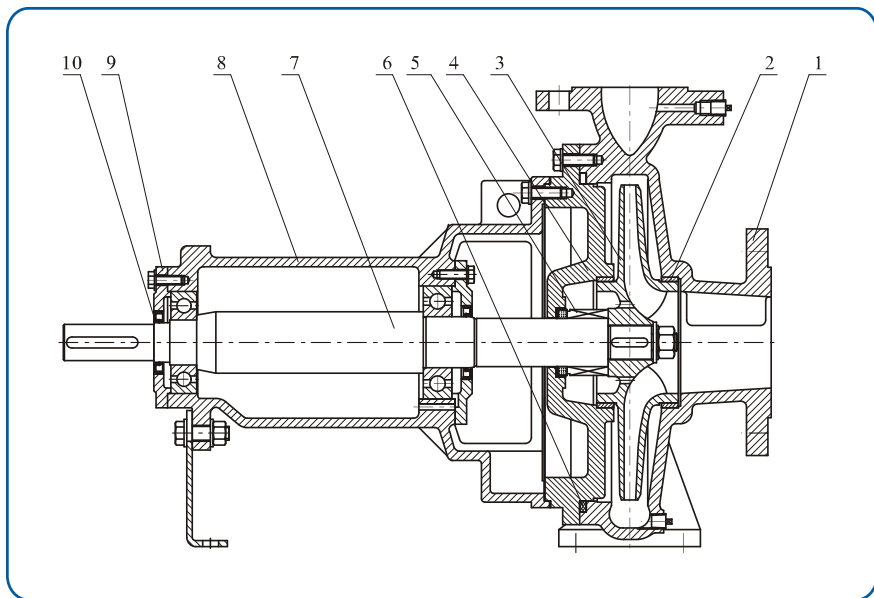

NISO零件材料

序号	零件名称	材料	对照代号 / AISI/ASTM
1	泵体	铸铁HT200	ASTM25B
2	耐磨环	铸铁HT200	ASTM25B
3	叶轮	铸铁HT200/ZG07Cr19Ni9	ASTM25B/AISI304
4	泵盖	铸铁HT200	ASTM25B
5	机械密封	石墨-碳化硅	
6	O形橡胶圈	丁腈橡胶NBR	
7	泵轴	不锈钢20Cr13	AISI420
8	悬架体	铸铁HT200	ASTM25B
9	轴承压盖	铸铁HT200	ASTM25B
10	油封	丁腈橡胶NBR	

NIS, NISF截面图

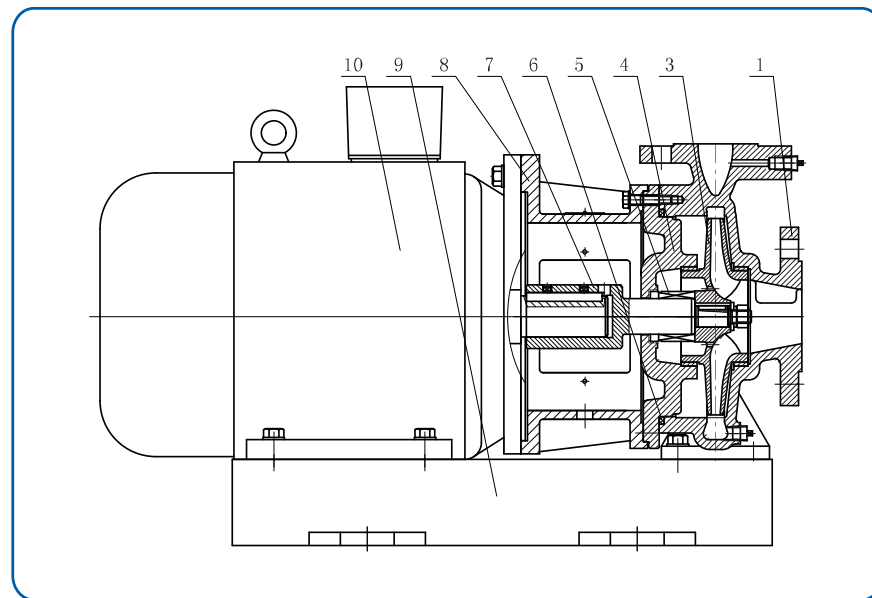

NIS, NISF零件材料

序号	零件名称	材料	对照代号 / AISI/ASTM
1	泵体	铸铁HT 200/ZG07Cr19Ni9	ASTM25B/AISI304
3	叶轮	HT200/ZG07Cr19Ni9	ASTM25B/AISI304
4	泵盖	铸铁HT 200/ZG07Cr19Ni9	ASTM25B/AISI304
5	机械密封	石墨-碳化硅	
6	O形橡胶圈	丁腈橡胶NBR	
7	泵轴	不锈钢20Cr13/06Cr19Ni10	AISI420/AISI304
8	泵头	铸铁HT200	ASTM25B
9	底座	Q235-A	AISA570
10	电机		

产品范围

2极

序号	泵型号	Q [m³/h]	H [m]	配用电机 [kW]	n [r/min]
1	50-32-160/3	12.5	28	3	2900
2	50-32-160/4		36	4	
3	50-32-160/5.5		44	5.5	
4	50-32-200/7.5		55	7.5	
5	50-32-200/11		74	11	2950
6	65-40-200/7.5	25	48	7.5	2900
7	65-40-200/11		62	11	2950
8	65-40-200/15		72	15	
9	65-40-250/18.5		84	18.5	
10	65-40-250/22		95	22	
11	65-40-250/30		105	30	
12	65-40-315/22		105	22	
13	65-40-315/30		120	30	
14	65-40-315/37		145	37	
15	65-40-315/45		165	45	
16	65-50-160/4		28	4	
17	65-50-160/5.5		36	5.5	
18	65-50-160/7.5		42	7.5	
19	80-50-200/11		50	44	11
20	80-50-200/15	57		15	
21	80-50-200/18.5	64		18.5	
22	80-50-200/22	71		22	
23	80-50-250/30	84		30	
24	80-50-250/37	100		37	
25	80-50-315/37	105		37	
26	80-50-315/45	125		45	
27	80-50-315/55	140		55	
28	80-50-315/75	152		75	

产品范围

2极

序号	泵型号	Q [m³/h]	H [m]	配用电机 [kW]	n [r/min]		
29	80-65-160/5.5	50	22	5.5	2900		
30	80-65-160/7.5		29	7.5			
31	80-65-160/11		38	11	2950		
32	80-65-160/15		44	15			
33	100-65-200/18.5	100	36	18.5	2950		
34	100-65-200/22		43	22			
35	100-65-200/30		56	30			
36	100-65-200/37		67	37			
37	100-65-250/45		80	45			
38	100-65-250/55		88	55			
39	100-65-250/75		108	75			
40	100-65-315/90		128	90			
41	100-65-315/110		148	110			
42	100-80-160/11		23	11			
43	100-80-160/15		30	15			
44	100-80-160/18.5		35	18.5			
45	100-80-160/22		40	22			
46	125-100-200/30		200	34		30	2950
47	125-100-200/37			41		37	
48	125-100-200/45			48		45	
49	125-100-200/55	55		55			
50	125-100-200/75	66		75			
51	125-100-250/75	75		75			
52	125-100-250/90	86		90			
53	125-100-250/110	100		110			
54	125-100-315/90	93		90			
55	125-100-315/110	108		110			
56	125-100-315/132	124		132			
57	125-100-315/160	144		160			

产品范围

4极

序号	泵型号	Q [m³/h]	H [m]	配用电机 [kW]	n [r/min]
1	50-32-160/0.55	6.3	8.5	0.55	1450
2	50-32-160/0.75		11	0.75	
3	50-32-200/1.1		14	1.1	
4	50-32-200/1.5		18	1.5	
5	65-40-200/1.1	12.5	12	1.1	
6	65-40-200/1.5		15	1.5	
7	65-40-200/2.2		17.5	2.2	
8	65-40-250/3		25	3	
9	65-40-315/4		34	4	
10	65-40-315/5.5		40	5.5	
11	65-50-160/0.55		7	0.55	
12	65-50-160/0.75		9	0.75	
13	65-50-160/1.1		10.5	1.1	
14	80-50-200/1.5		25	11	1.5
15	80-50-200/2.2	15		2.2	
16	80-50-200/3	17.5		3	
17	80-50-250/4	21		4	
18	80-50-250/5.5	25		5.5	
19	80-50-315/5.5	30		5.5	
20	80-50-315/7.5	37		7.5	
21	80-65-160/0.75	6		0.75	
22	80-65-160/1.1	8		1.1	
23	80-65-160/1.5	10.5		1.5	
24	100-65-200/3	50	11.5	3	
25	100-65-200/4		14	4	
26	100-65-200/5.5		16	5.5	
27	100-65-250/5.5		20	5.5	
28	100-65-250/7.5		25	7.5	
29	100-65-315/11		32	11	
30	100-65-315/15		40	15	
31	100-80-160/1.5		6.5	1.5	
32	100-80-160/2.2		9	2.2	
33	100-80-160/3		10.5	3	

产品范围

4极

序号	泵型号	Q [m³/h]	H [m]	配用电机 [kW]	n [r/min]	
34	125-80-400/15	50	39	15	1480	
35	125-80-400/18.5		45	18.5		
36	125-80-400/22		50	22		
37	125-80-400/30		60	30		
38	125-80-400/37		67	37		
39	125-100-200/4	100	9	4	1450	
40	125-100-200/5.5		11.5	5.5		
41	125-100-200/7.5		14	7.5		
42	125-100-200/11		16.5	11		
43	125-100-250/15		25	15		
44	125-100-315/11		23	11	1480	
45	125-100-315/18.5		32	18.5		
46	125-100-315/22		36	22		
47	125-100-315/30		40	30		
48	125-100-400/30		50	30		
49	125-100-400/37	58	37			
50	125-100-400/45	65	45			
51	150-125-250/11	200	12.5	11		1480
52	150-125-250/15		16	15		
53	150-125-250/18.5		20	18.5		
54	150-125-250/22		24	22		
55	150-125-315/30		32	30		
56	150-125-315/37		39	37		
57	150-125-400/45		50	45		
58	150-125-400/55		57	55		
59	150-125-400/75		68	75		
60	200-150-315/37		400	23	37	
61	200-150-315/45	27		45		
62	200-150-315/55	32		55		
63	200-150-315/75	38		75		
64	200-150-400/75	43		75		
65	200-150-400/90	50		90		
66	200-150-400/110	62		110		
67	250-200-315/37	500	20	37	1480	
68	250-200-315/45		23	45		
69	250-200-315/55		24	55		
70	250-200-315/75		32	75		
71	250-200-400/90		37	90		
72	250-200-400/110		44	110		
73	250-200-400/132		53	132		
74	250-200-400/160		60	160		

50-32-160/50-32-200

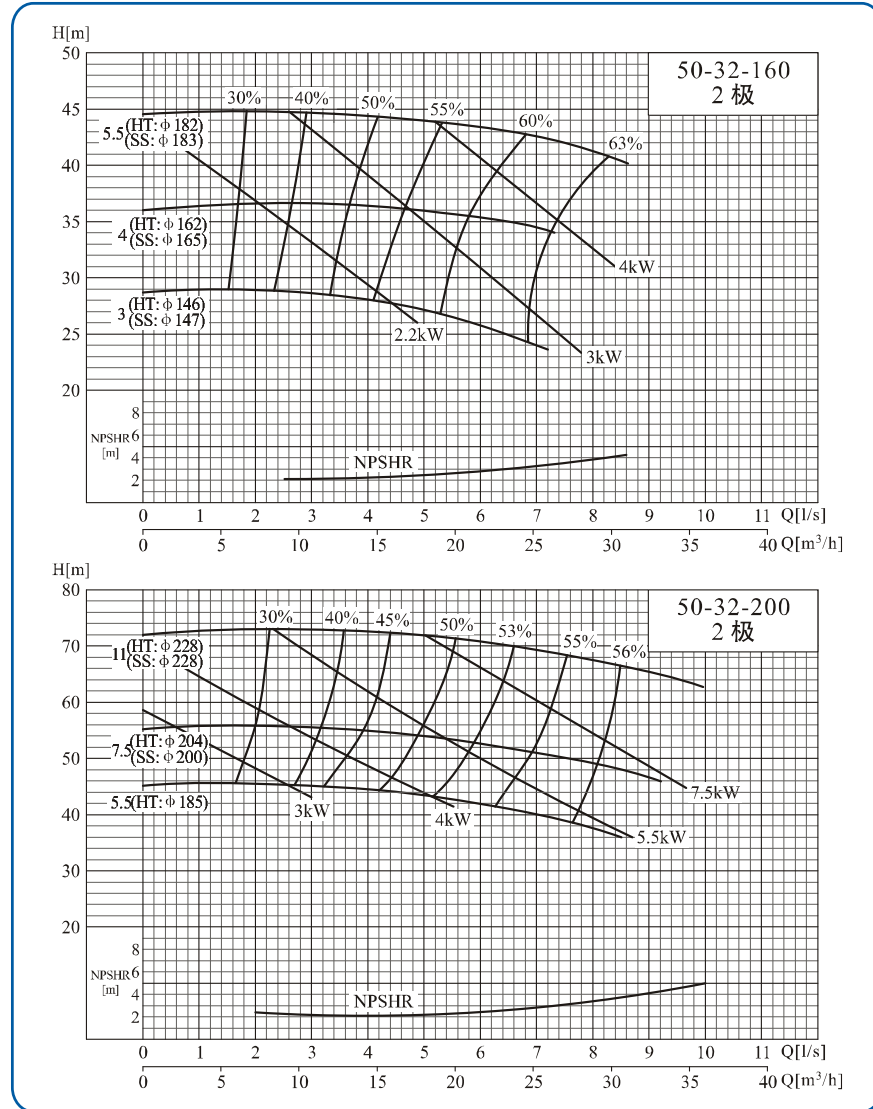

65-40-200/65-40-250

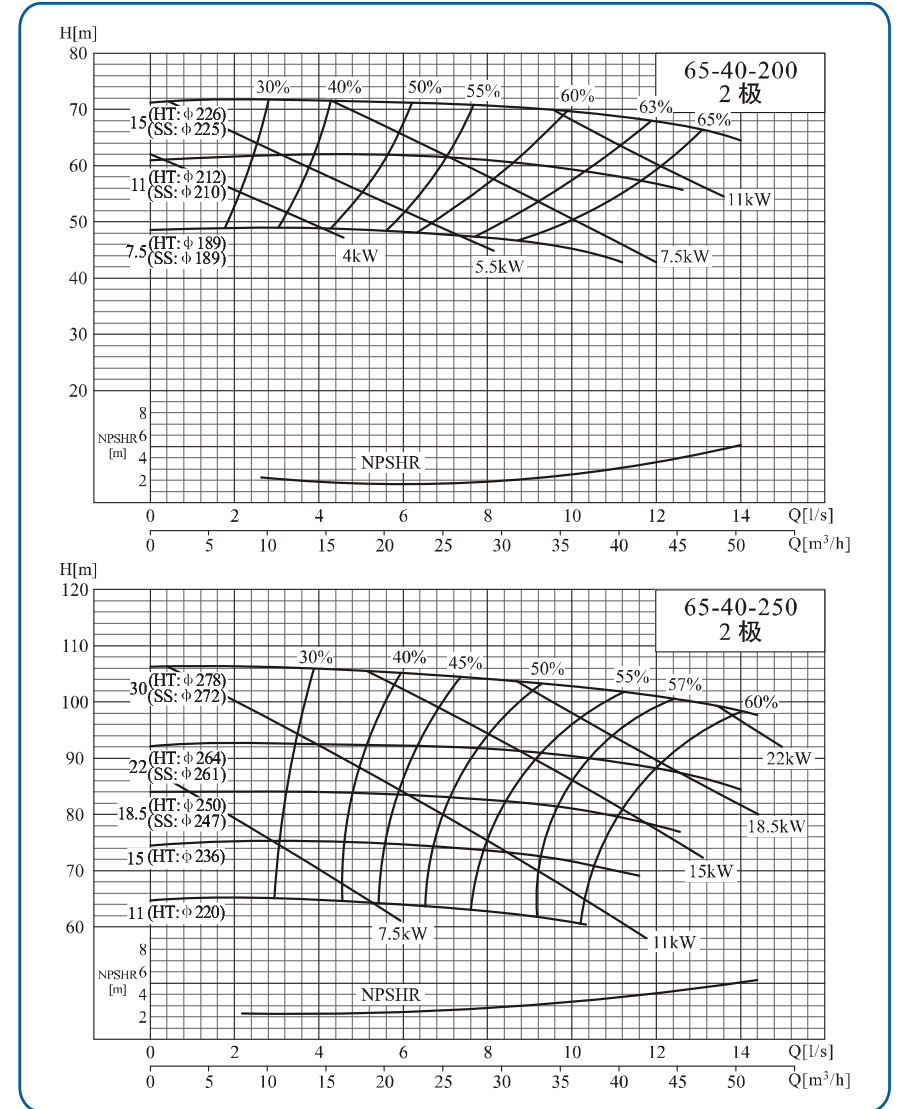

65-40-315/65-50-160

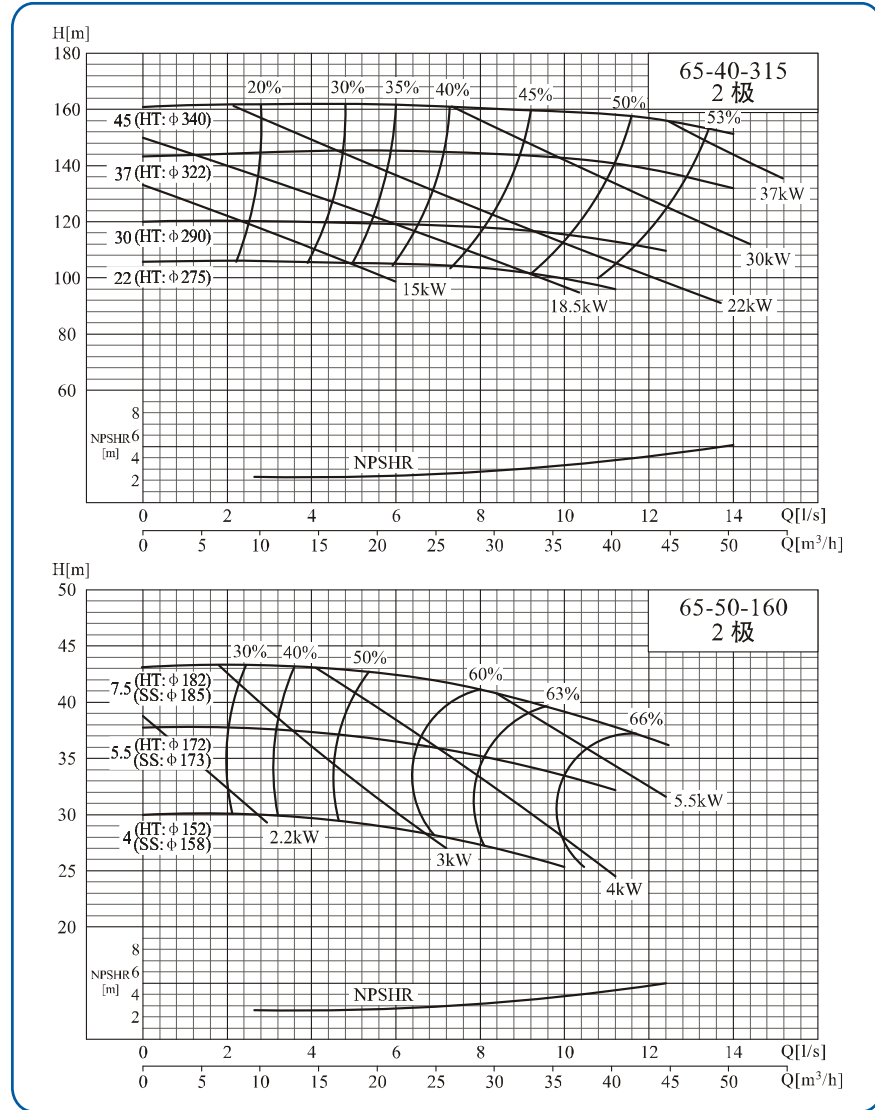

80-50-200/80-50-250

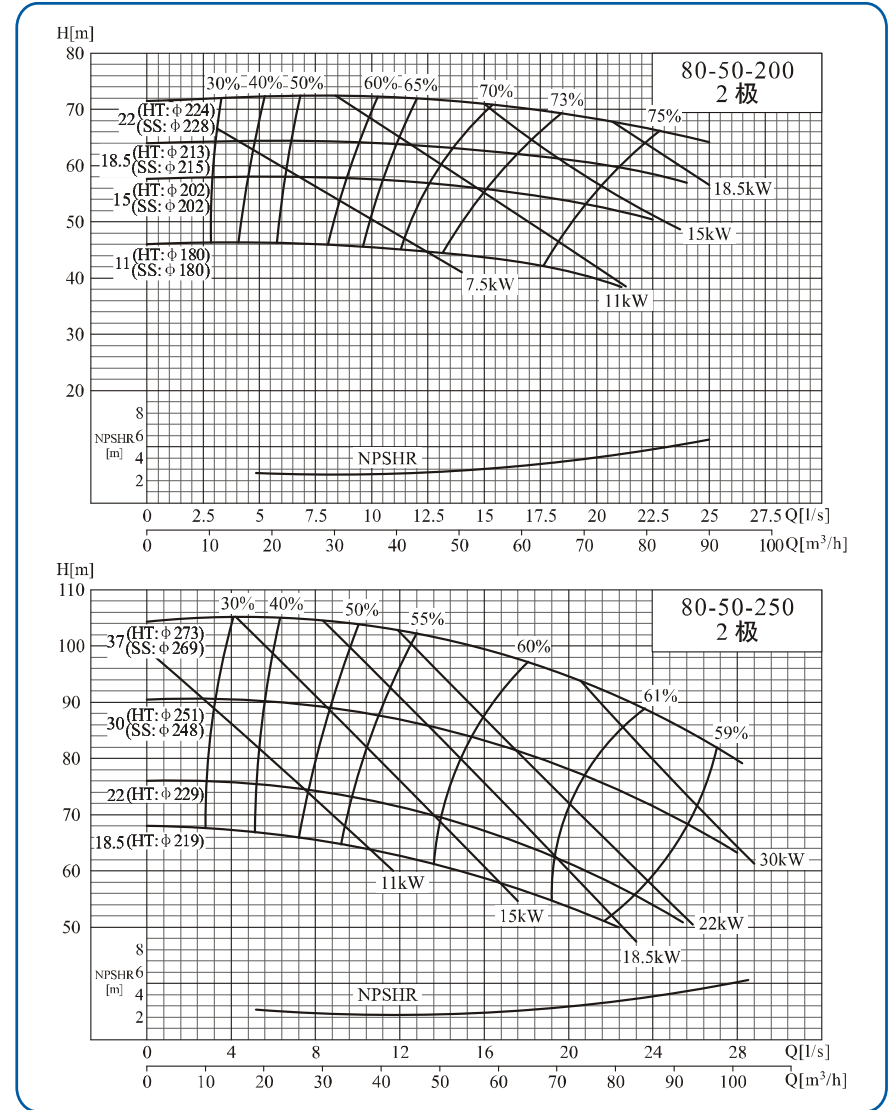

80-50-315/80-65-160

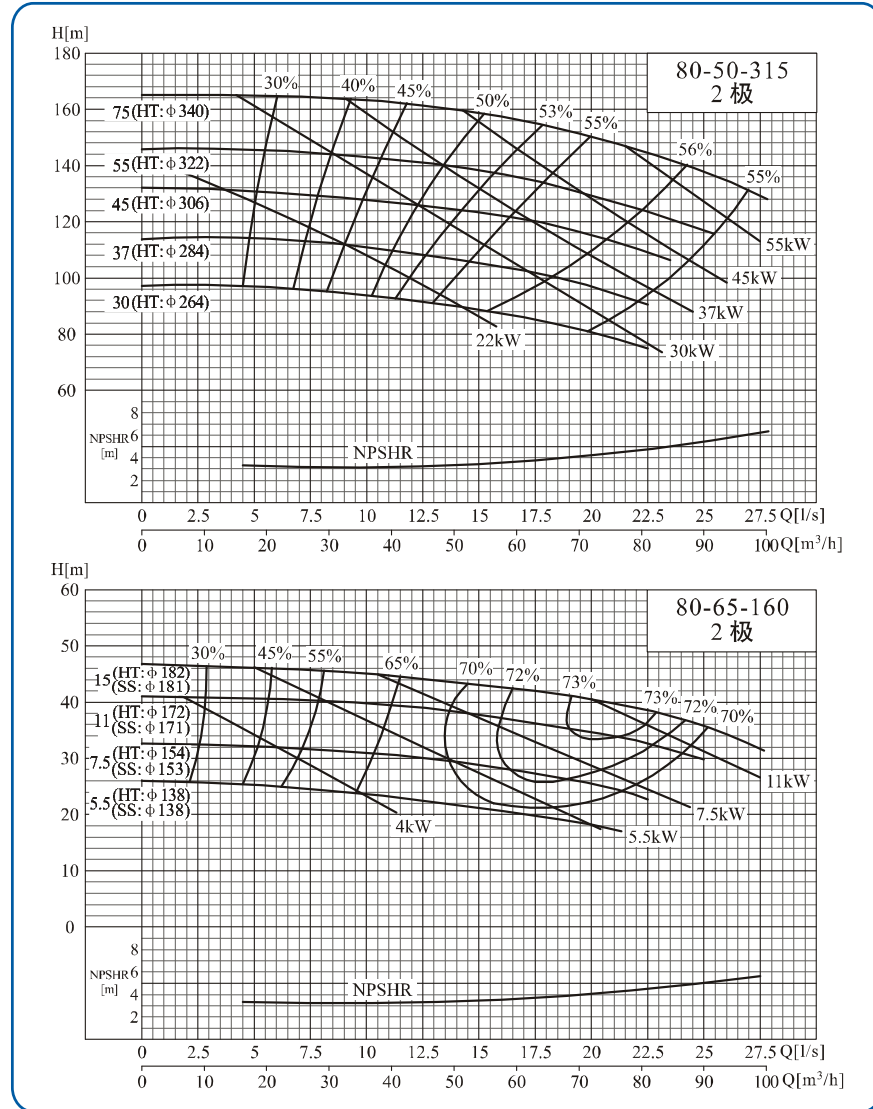

100-65-200/100-65-250

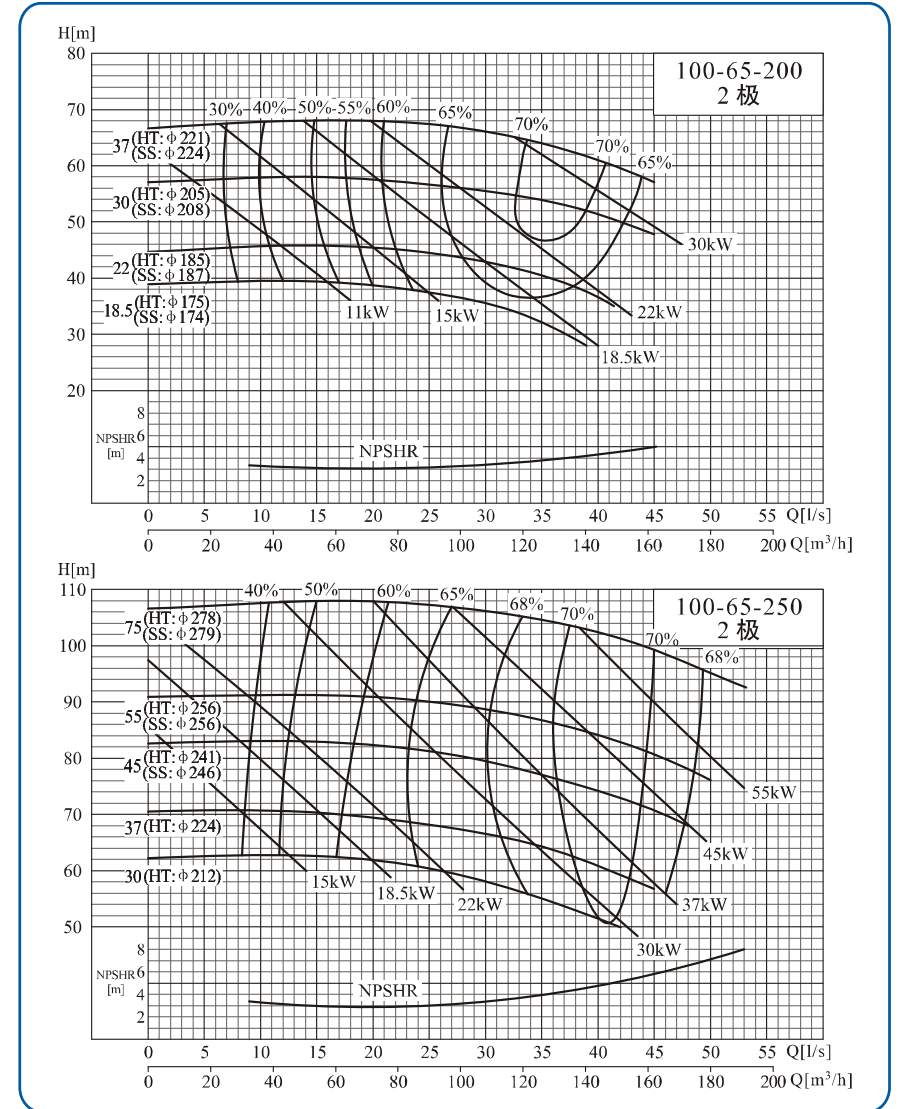

100-65-315/100-80-160

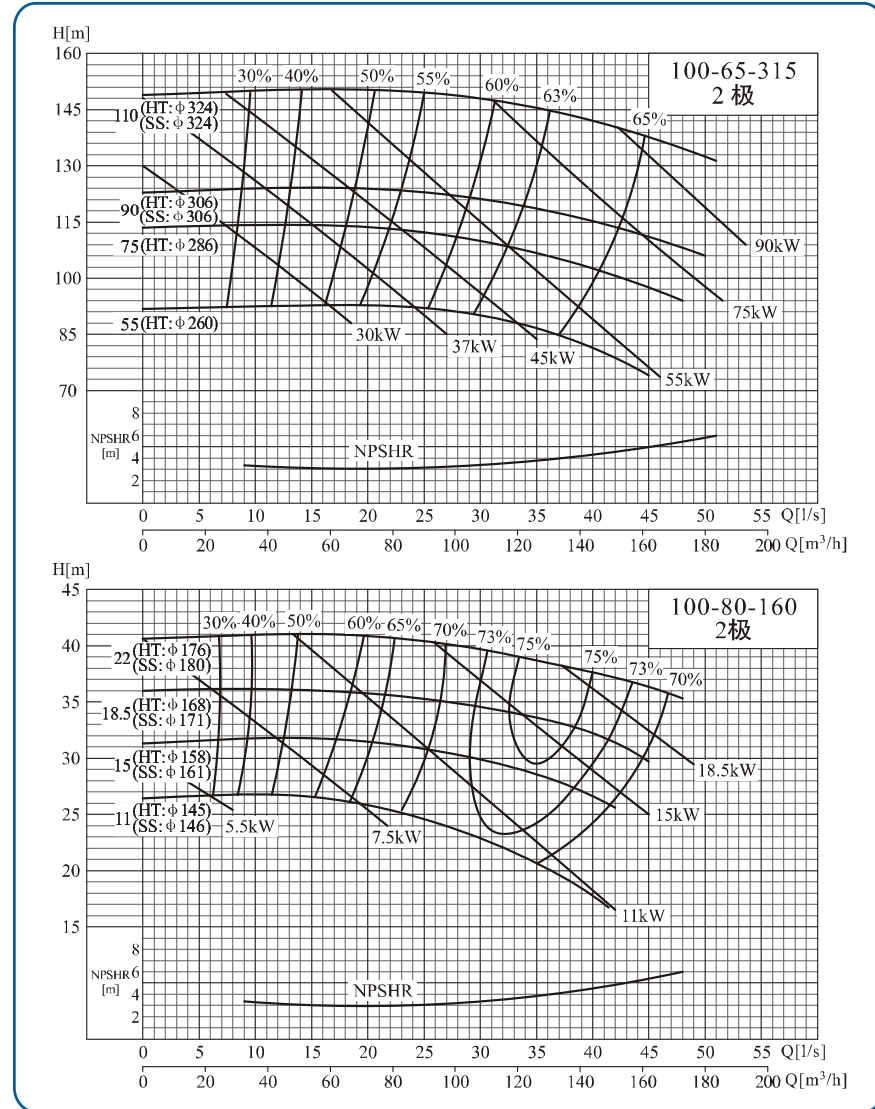

125-100-200/125-100-250

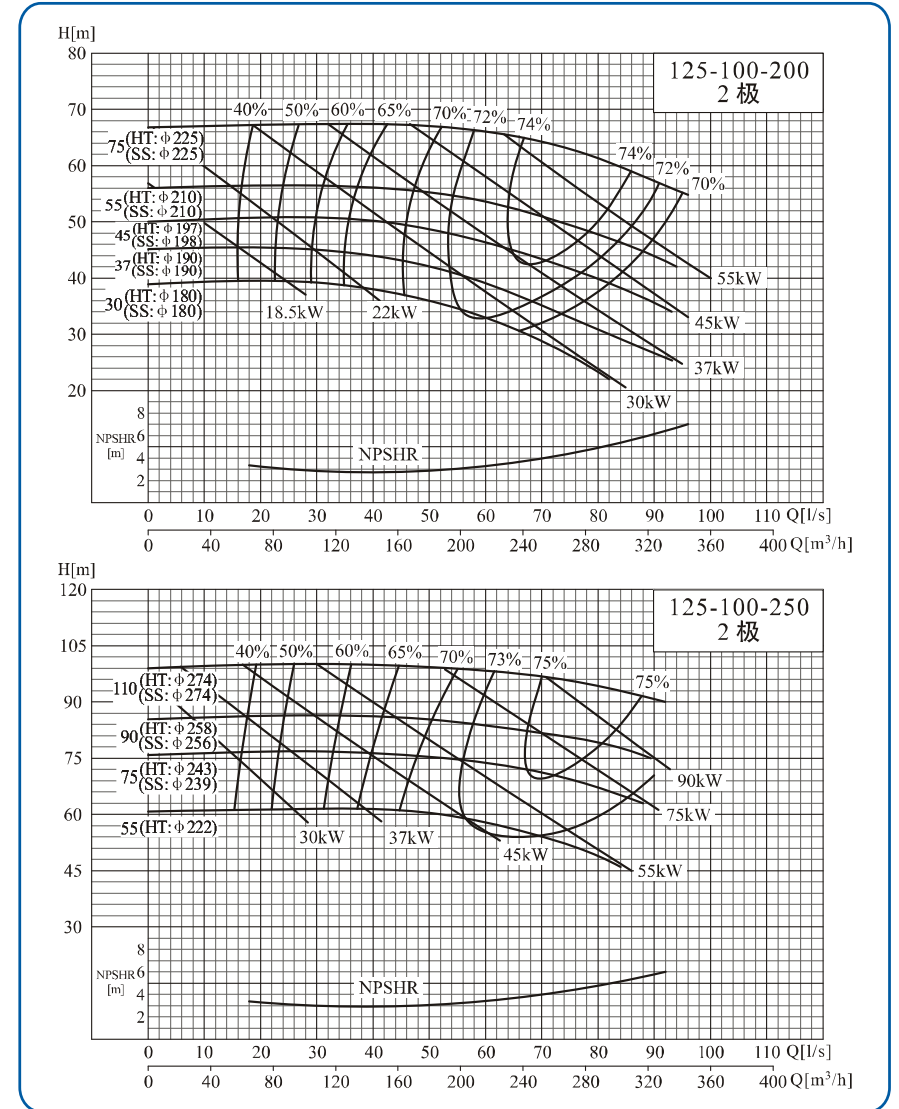

125-100-315/50-32-160

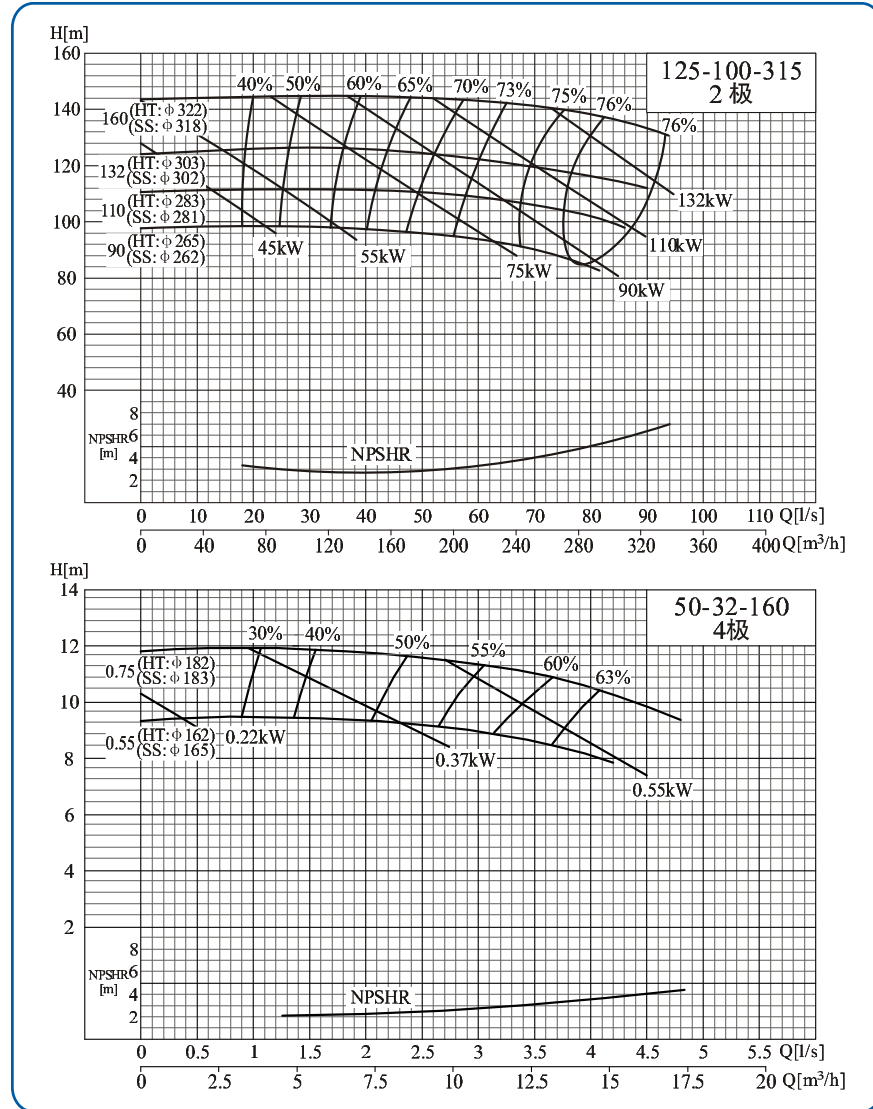

50-32-200/65-40-200

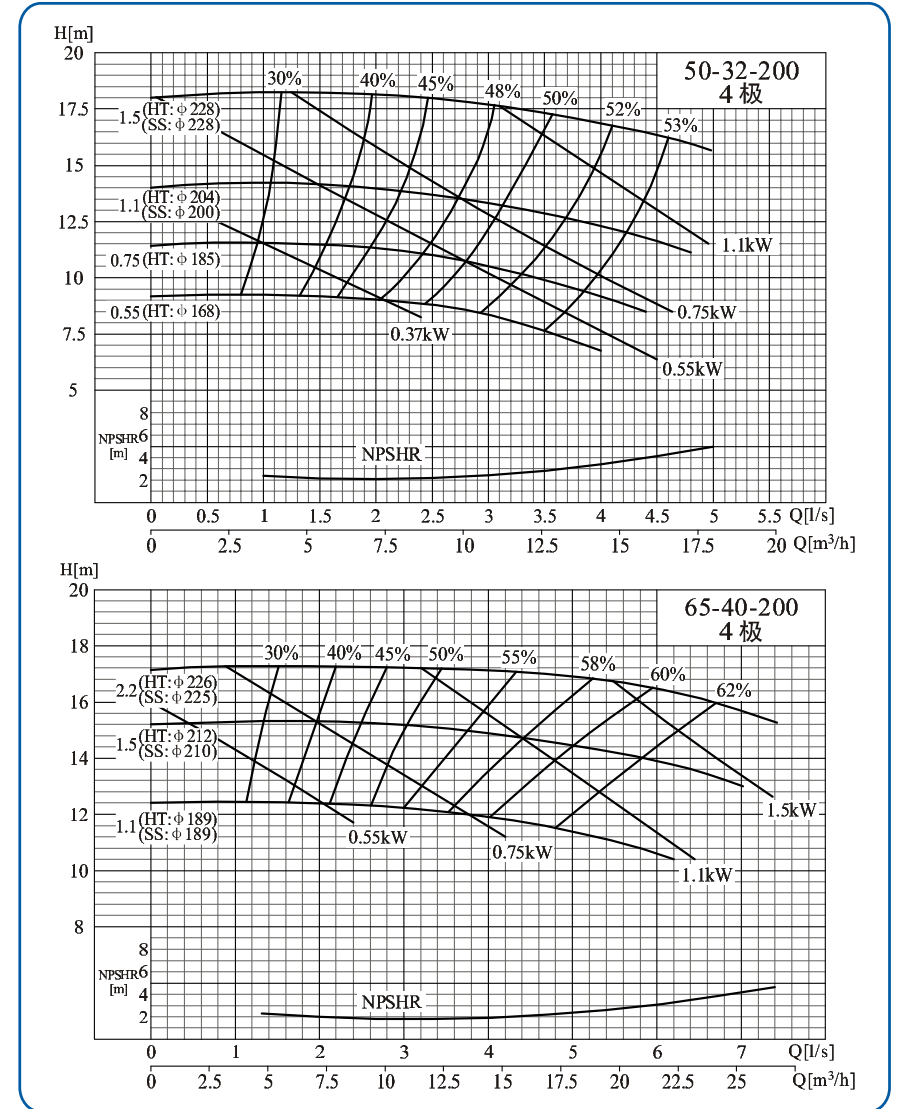

65-40-250/65-40-315

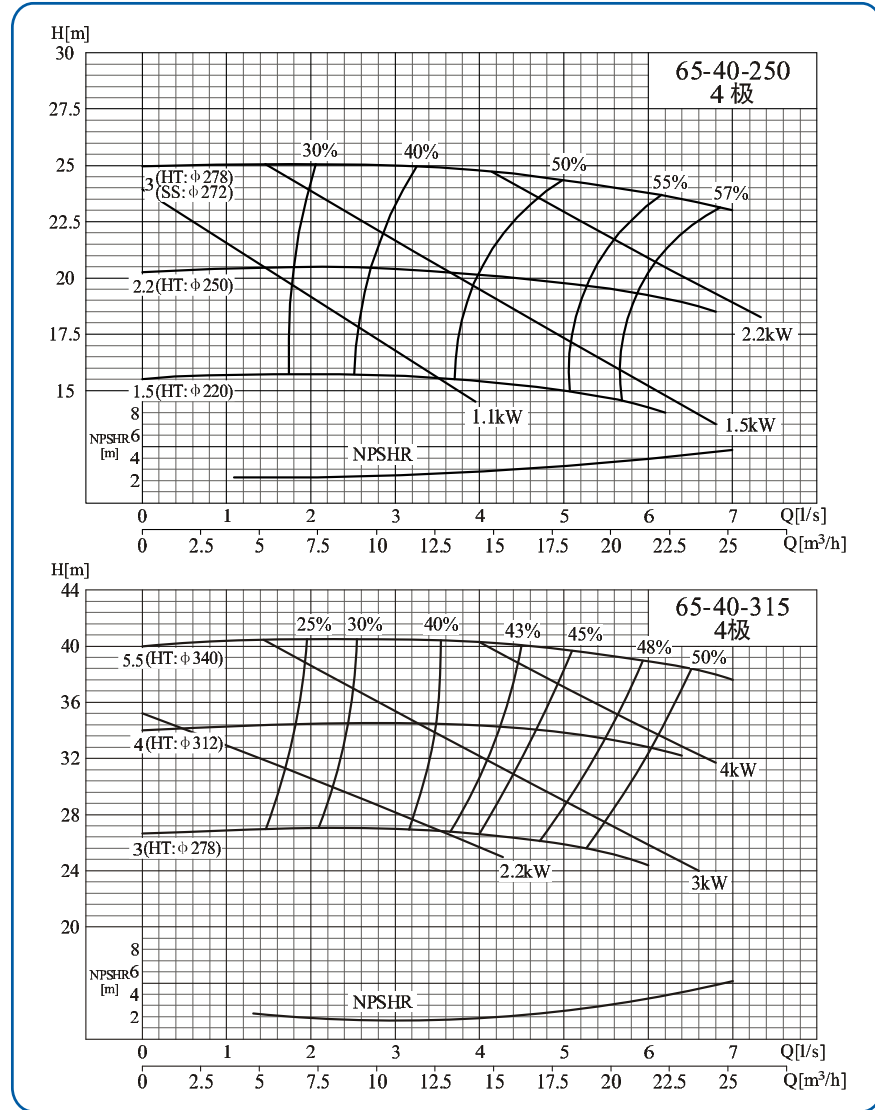

65-50-160/80-50-200

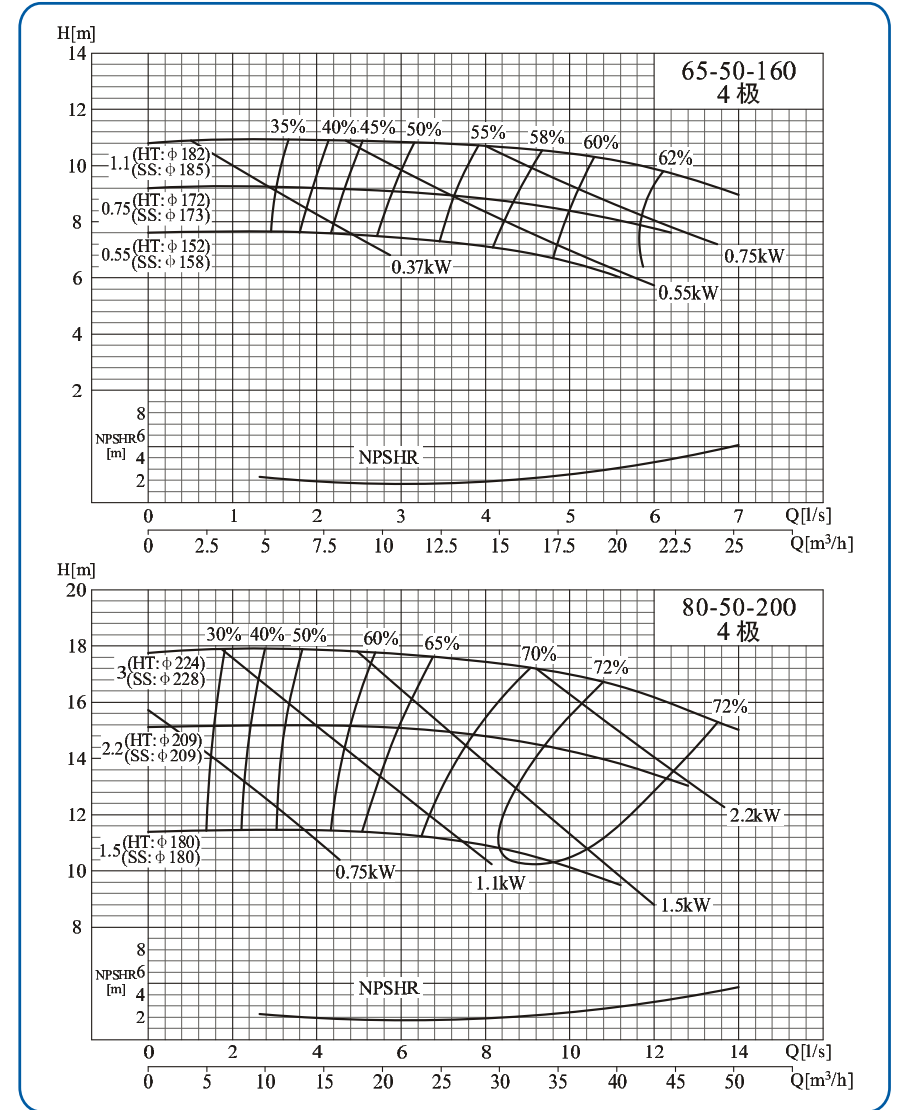

80-50-250/80-50-315

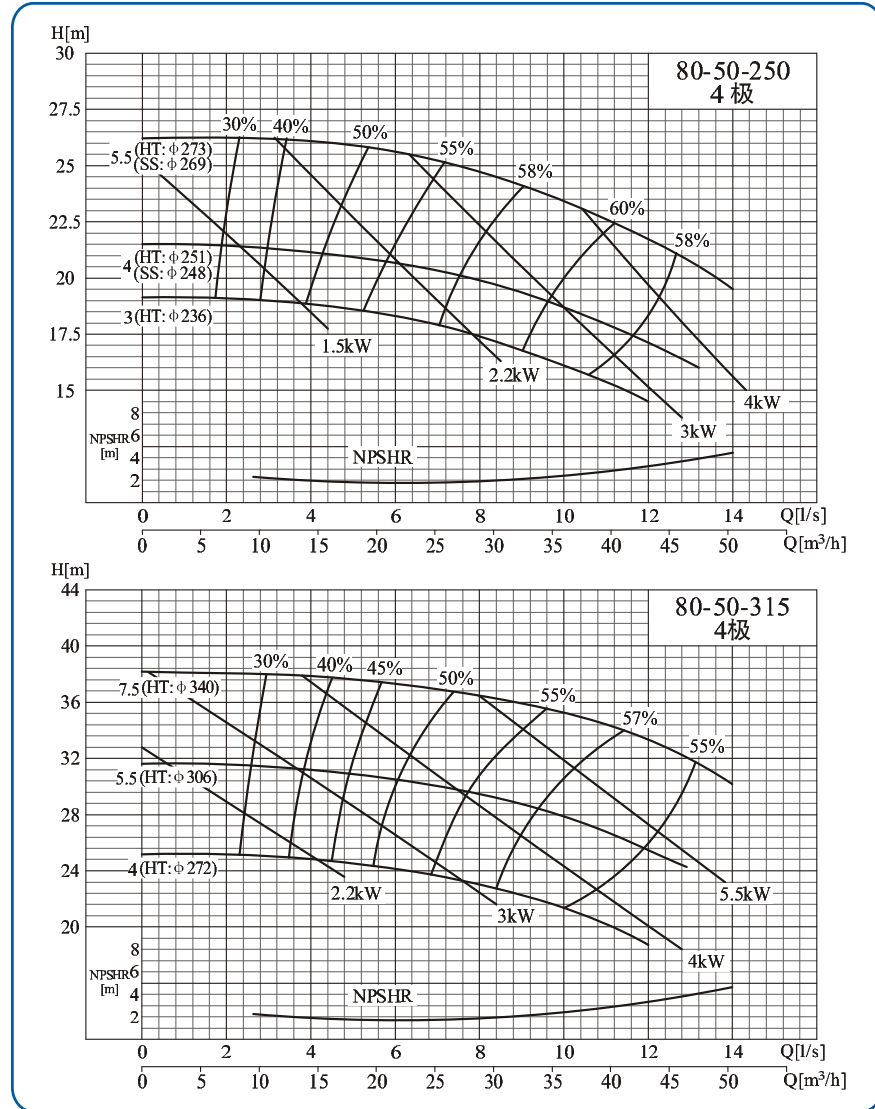

80-65-160/100-65-200

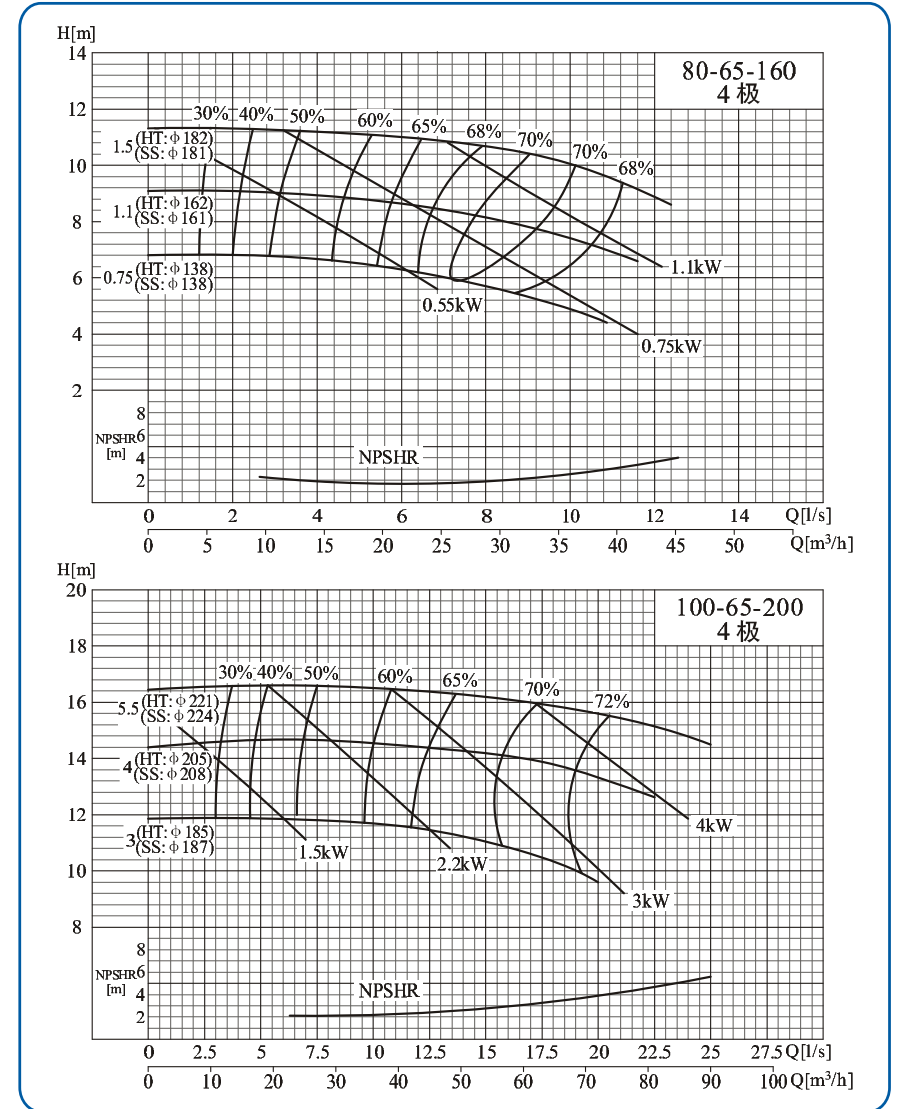

100-65-250/100-65-315

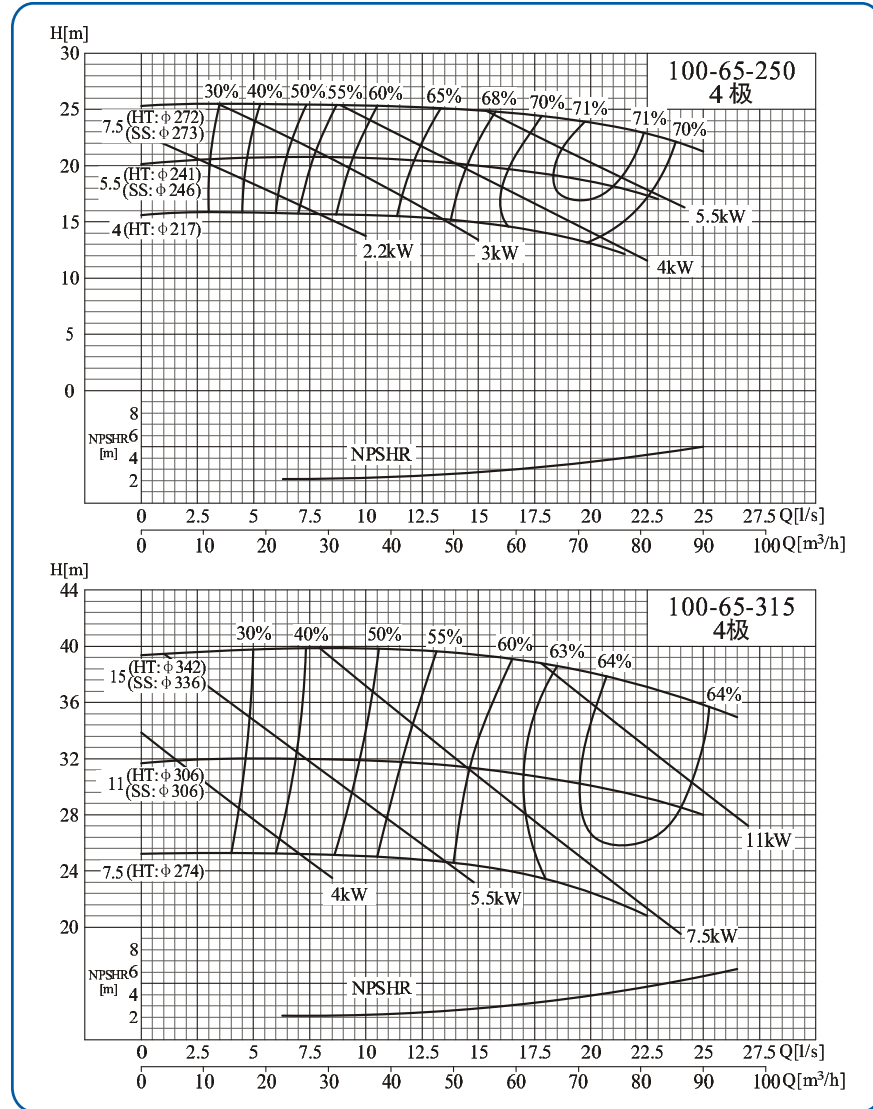

100-80-160/125-100-200

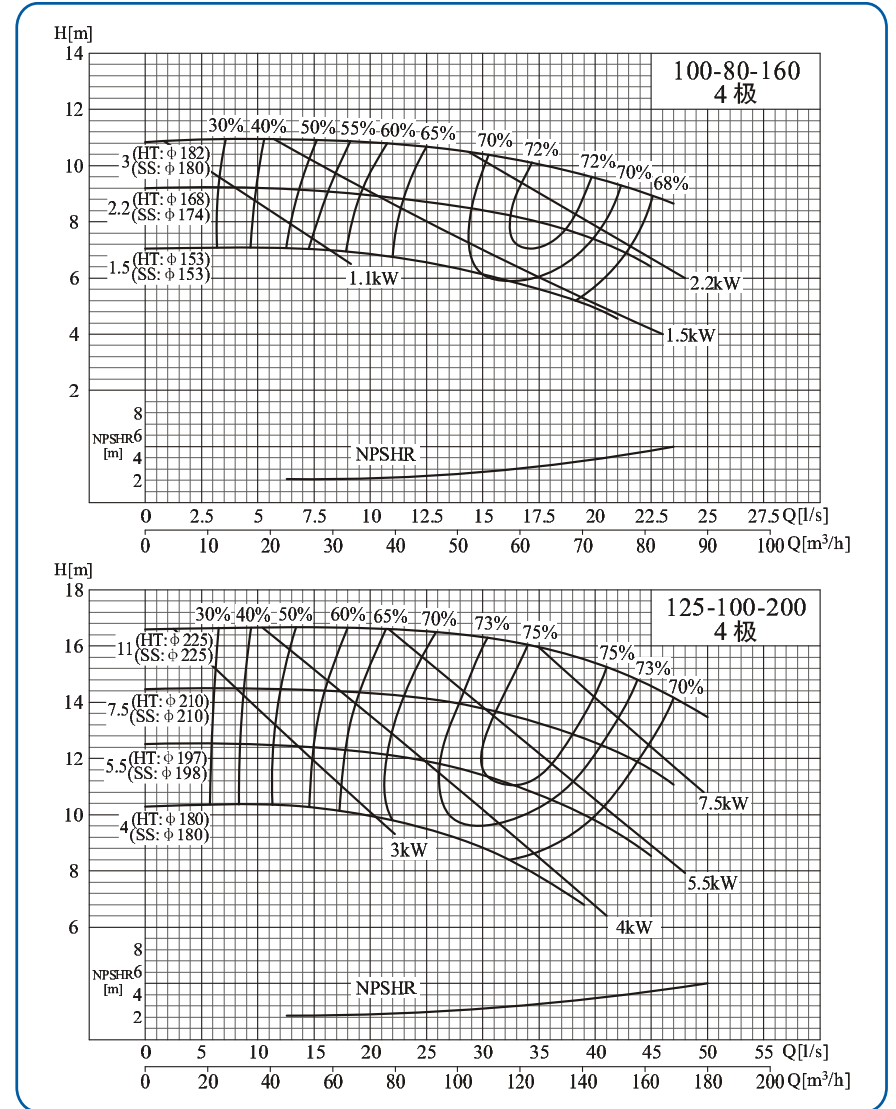

125-100-250/125-100-315

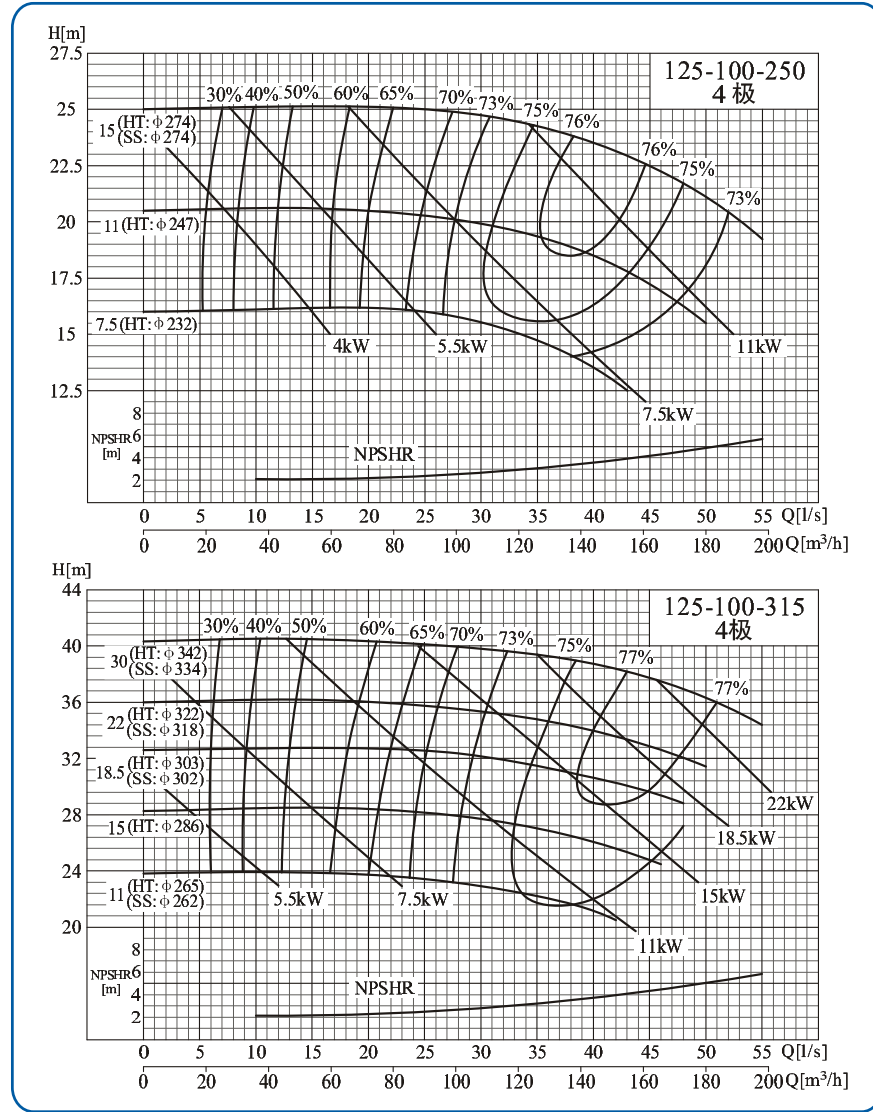

125-80-400/125-100-400

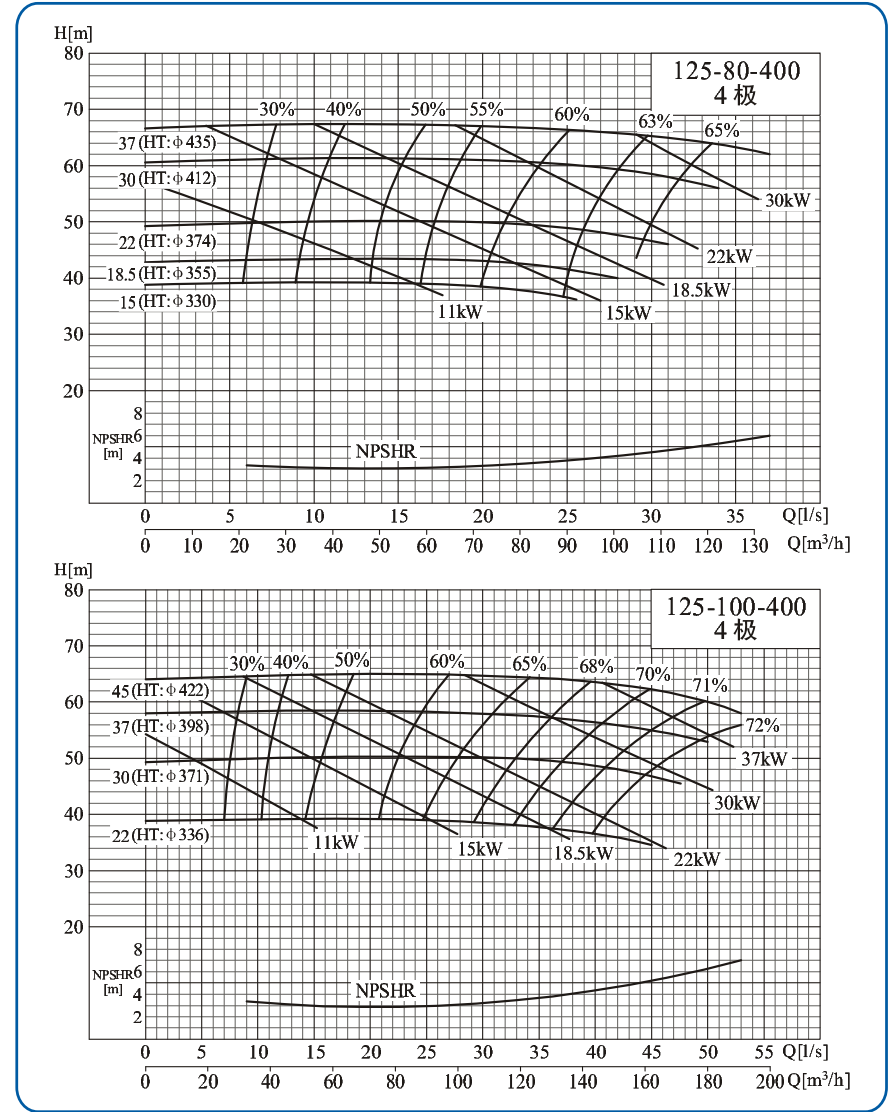

150-125-250/150-125-315

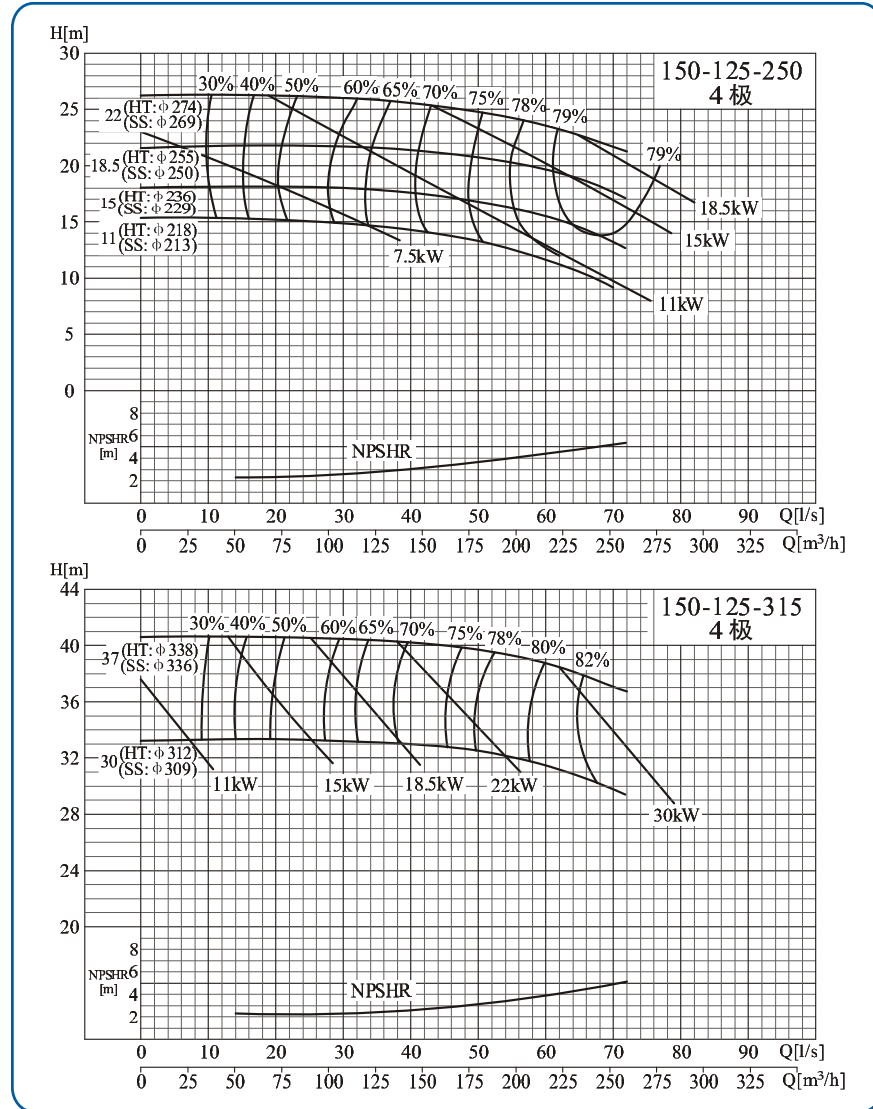

150-125-400/200-150-315

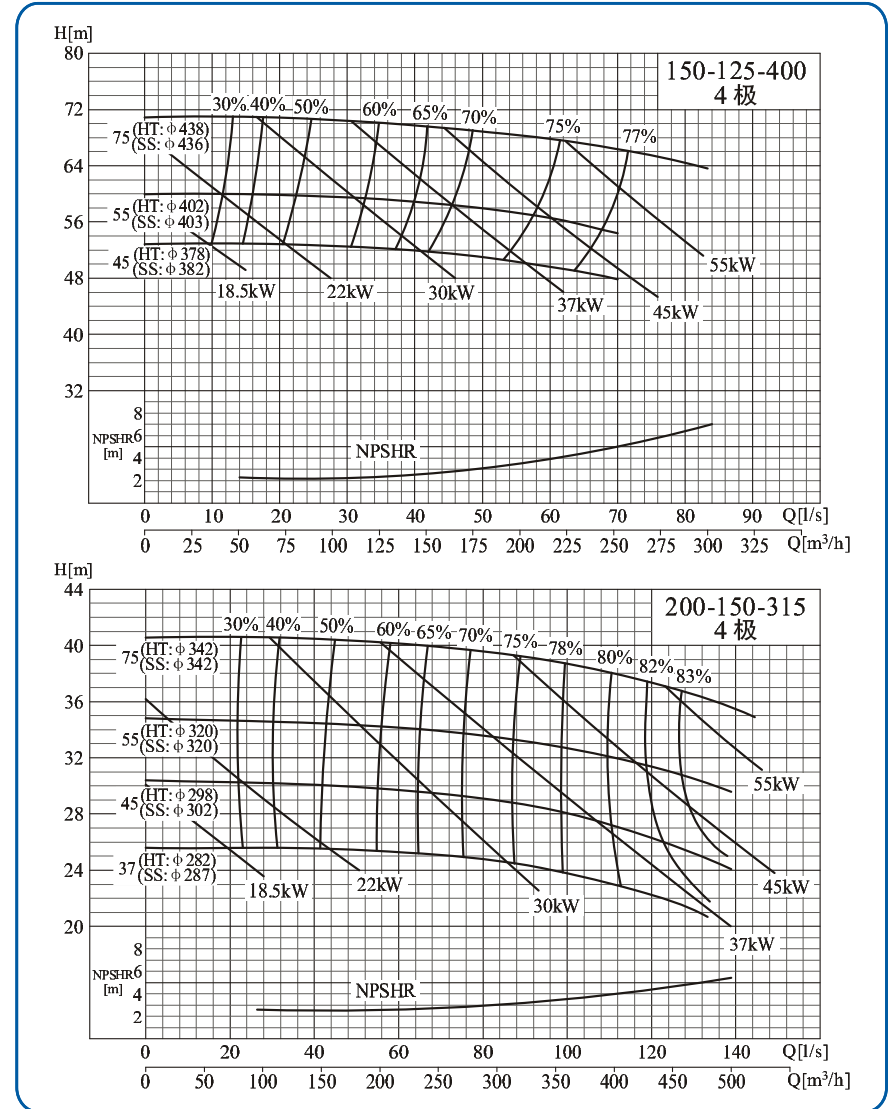

200-150-400/250-200-315

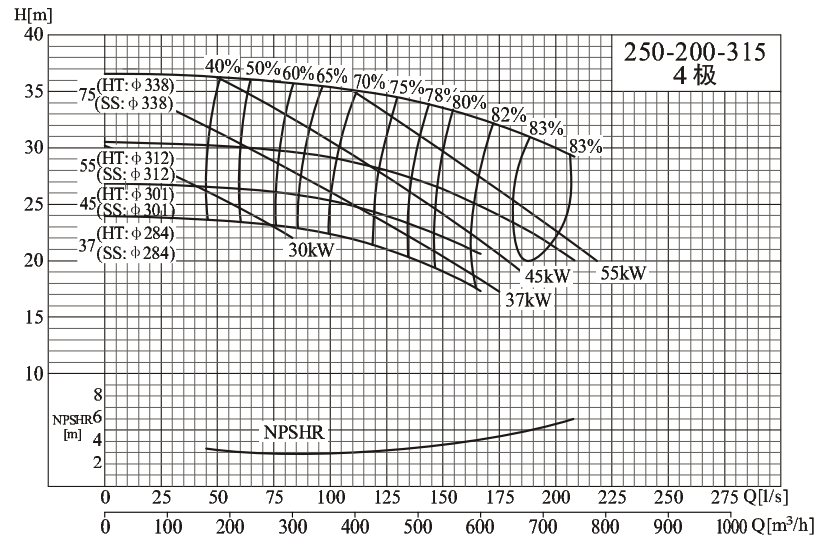
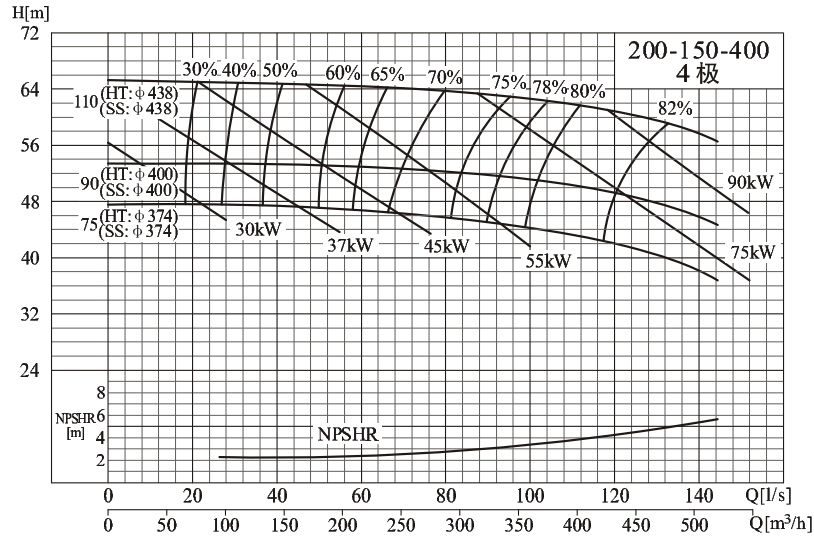

250-200-400

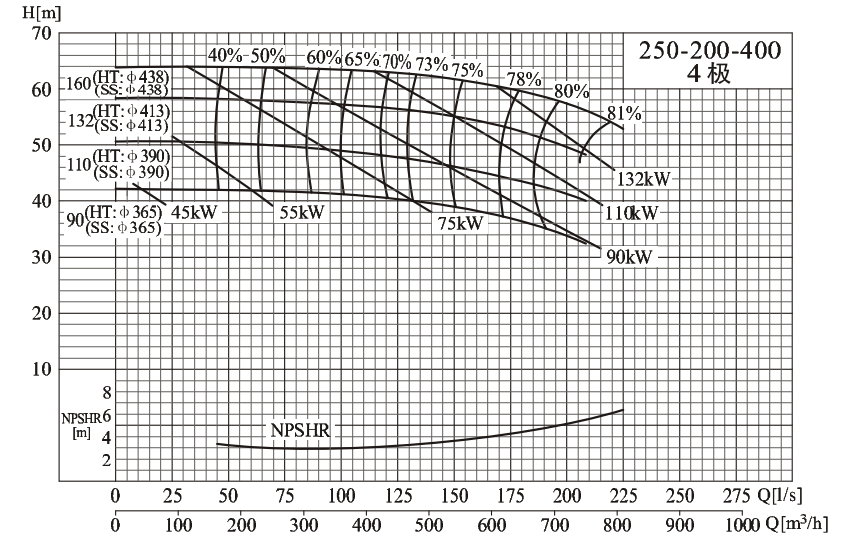

NISO泵外形尺寸图

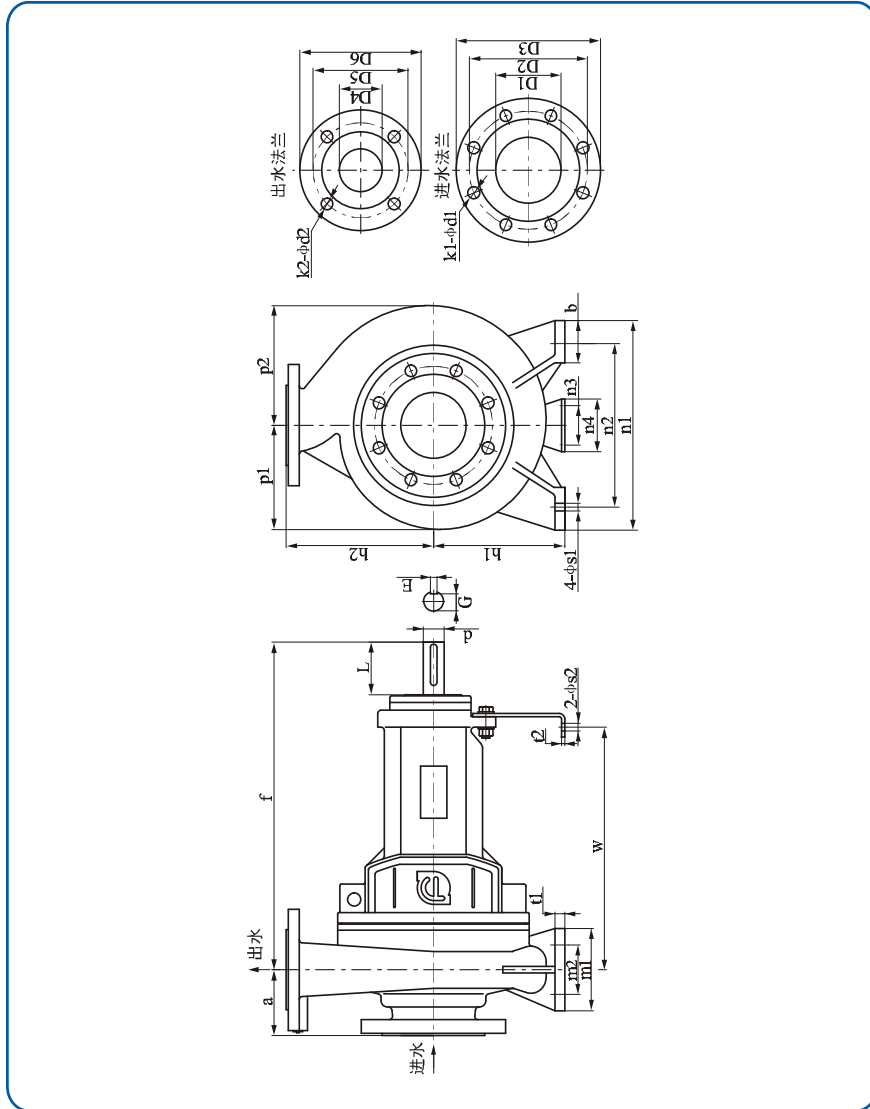

NISO泵外形尺寸表

序号	泵型号	泵外形尺寸						泵底板及安装尺寸											
		a	f	h1	h2	b	p1	p2	m1	m2	n1	n2	n3	n4	t1	t2	w	s1	s2
1	50-32-160	80	385	132	160	50	118	128	100	70	240	190	110	160	12	6	285	14	14
2	50-32-200	80	385	160	180	50	139	147	100	70	240	190	110	160	12	6	285	14	14
3	65-50-160	80	385	132	160	50	121	136	100	70	240	190	110	160	12	6	285	14	14
4	65-40-200	100	385	160	180	50	140	151	100	70	265	212	110	160	13	6	285	14	14
5	65-40-250	100	500	180	225	65	166	176	125	95	320	250	110	160	14	6	370	14	14
6	65-40-315	125	500	200	250	65	194	200	125	95	345	280	110	160	16	6	370	14	14
7	80-65-160	100	385	160	180	50	124	143	100	70	265	212	110	160	13	6	285	14	14
8	80-50-200	100	385	160	200	52	147	161	100	70	265	212	110	160	13	6	285	14	14
9	80-50-250	125	500	180	225	65	167	179	125	95	320	250	110	160	15	6	370	14	14
10	80-50-315	125	500	225	280	65	204	215	125	95	345	280	110	160	18	6	370	14	14
11	100-65-200	100	500	180	225	65	159	183	125	95	320	250	110	160	14	6	370	14	14
12	100-65-250	125	500	200	250	80	180	201	160	120	360	280	110	160	16	6	370	18	14
13	100-65-315	125	530	225	280	80	210	228	160	120	400	315	110	160	18	6	370	18	14
14	100-80-160	100	500	160	200	65	132	160	125	95	280	212	110	160	14	6	370	14	14
15	125-80-400	125	530	280	355	80	261	279	160	120	435	355	110	160	20	6	370	18	14
16	125-100-200	125	500	200	280	80	175	210	160	120	360	280	110	160	17	6	370	18	14
17	125-100-250	140	530	225	280	80	193	225	160	120	400	315	110	160	18	6	370	18	14
18	125-100-315	140	530	250	315	80	224	250	160	120	400	315	110	160	19	6	370	18	14
19	125-100-400	140	530	280	355	100	265	287	200	150	500	400	110	160	20	6	370	18	14
20	150-125-250	140	530	250	355	80	204	244	160	120	400	315	110	160	19	6	370	18	14
21	150-125-315	140	530	280	355	100	236	271	200	150	500	400	110	160	20	6	370	22	14
22	150-125-400	140	530	315	400	100	273	301	200	150	500	400	110	160	21	6	370	22	14
23	200-150-315	160	670	315	400	82	255	304	200	150	515	450	140	180	25	10	500	22	18
24	200-150-400	160	670	315	450	82	291	330	200	150	515	450	140	180	25	10	500	22	18
25	250-200-315	180	670	315	450	82	278	344	200	150	515	450	140	180	25	10	500	22	18
26	250-200-400	180	670	380	450	82	314	367	200	150	515	450	140	180	25	10	500	22	18

续表

序号	泵型号	进水法兰尺寸					出水法兰尺寸					轴伸端尺寸				重量 (kg)
		D1	D2	D3	k1	d1	D4	D5	D6	k2	d2	D	L	E	G	
1	50-32-160	50	125	165	4	18	32	100	140	4	18	24	50	8	20	40
2	50-32-200	50	125	165	4	18	32	100	140	4	18	24	50	8	20	48
3	65-50-160	65	145	185	4	18	50	125	165	4	18	24	50	8	20	42
4	65-40-200	65	145	185	4	18	40	110	150	4	18	24	50	8	20	50
5	65-40-250	65	145	185	4	18	40	110	150	4	18	32	80	10	27	72
6	65-40-315	65	145	185	4	18	40	110	150	4	18	32	80	10	27	82
7	80-65-160	80	160	200	8	18	65	145	185	4	18	24	50	8	20	48
8	80-50-200	80	160	200	8	18	50	125	165	4	18	24	50	8	20	54
9	80-50-250	80	160	200	8	18	50	125	165	4	18	32	80	10	27	75
10	80-50-315	80	160	200	8	18	50	125	165	4	18	32	80	10	27	90
11	100-65-200	100	180	220	8	18	65	145	185	4	18	32	80	10	27	73
12	100-65-250	100	180	220	8	18	65	145	185	4	18	32	80	10	27	82
13	100-65-315	100	180	220	8	18	65	145	185	4	18	42	110	12	37	120
14	100-80-160	100	180	220	8	18	80	160	200	8	18	32	80	10	27	70
15	125-80-400	125	210	250	8	18	80	160	200	8	18	42	110	12	37	168
16	125-100-200	125	210	250	8	18	100	180	220	8	18	32	80	10	27	88
17	125-100-250	125	210	250	8	18	100	180	220	8	18	42	110	12	37	130
18	125-100-315	125	210	250	8	18	100	180	220	8	18	42	110	12	37	138
19	125-100-400	125	210	250	8	18	100	180	220	8	18	42	110	12	37	178
20	150-125-250	150	240	285	8	22	125	210	250	8	18	42	106	12	37	134
21	150-125-315	150	240	285	8	22	125	210	250	8	18	42	106	12	37	167
22	150-125-400	150	240	285	8	22	125	210	250	8	18	42	106	12	37	186
23	200-150-315	200	295	340	12	22	150	240	285	8	22	60	110	18	53	228
24	200-150-400	200	295	340	12	22	150	240	285	8	22	60	110	18	53	285
25	250-200-315	250	355	405	12	26	200	295	340	12	22	60	110	18	53	264
26	250-200-400	250	355	405	12	26	200	295	340	12	22	60	110	18	53	335

NISO泵组外形尺寸图

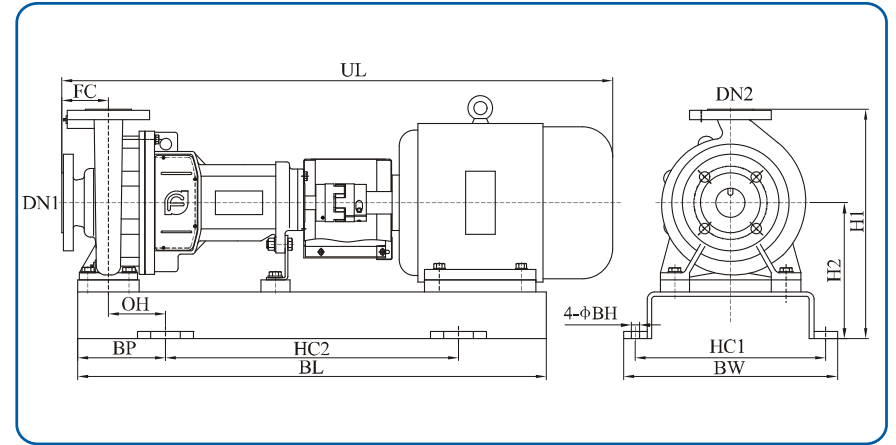

NISO泵组外形尺寸表

2极

型号	功率 (kW)	H1	H2	HC1	HC2	BW	BL	BP	BH	OH	UL	FC	DN1	DN2	总重量 (kg)
50-32-160	3	392	232	296	500	336	750	125	14	72.5	857	80	50	32	94
	4	392	232	296	500	336	750	125	14	72.5	875	80	50	32	100
	5.5	392	232	325	500	365	800	150	14	97.5	941	80	50	32	124
50-32-200	7.5	440	243	340	600	380	860	130	14	77.5	941	80	50	32	139
	11	440	260	380	600	420	950	175	18	121	1077	80	50	32	195
65-40-200	7.5	440	260	325	500	365	800	150	14	97.5	961	100	65	40	140
	11	440	260	380	600	420	950	175	18	121	1097	100	65	40	197
	15	440	260	380	600	420	950	175	18	121	1097	100	65	40	207
65-40-250	18.5	505	280	380	800	420	1080	140	18	73.5	1282	100	65	40	253
	22	505	280	420	800	480	1100	150	18	81.5	1319	100	65	40	289
	30	525	300	460	800	500	1180	190	18	121.5	1379	100	65	40	349
65-40-315	22	550	300	420	800	460	1100	150	18	81.5	1344	125	65	40	301
	30	570	320	455	800	495	1200	200	18	131.5	1412	125	65	40	372
	37	570	320	455	800	495	1200	200	18	131.5	1412	125	65	40	391
65-40-315	45	590	340	510	800	560	1250	225	22	155	1466	125	65	40	459
	4	392	232	296	500	336	750	125	14	72.5	875	80	65	50	102
	5.5	392	232	325	500	365	800	150	14	97.5	941	80	65	50	126
65-50-160	7.5	392	232	325	500	365	800	150	14	97.5	941	80	65	50	129

续表

2 极

型号	功率 (kW)	H1	H2	HC1	HC2	BW	BL	BP	BH	OH	UL	FC	DN1	DN2	总重量 (kg)
80-50-200	11	460	260	380	600	420	950	175	18	121	1097	100	80	50	201
	15	460	260	380	600	420	950	175	18	121	1097	100	80	50	211
	18.5	460	260	380	600	420	950	175	18	121	1137	100	80	50	230
	22	480	280	420	700	460	1000	150	18	96	1194	100	80	50	273
80-50-250	30	525	300	460	800	500	1180	190	18	121.5	1404	125	80	50	351
	37	525	300	460	800	495	1180	190	18	121.5	1404	125	80	50	370
80-50-315	37	625	345	455	800	495	1200	200	18	131.5	1402	125	80	50	402
	45	625	345	510	800	560	1250	225	22	155	1466	125	80	50	466
	55	650	370	575	900	625	1300	200	22	130	1547	125	80	50	566
	75	680	400	620	800	670	1400	300	22	230	1620	125	80	50	706
80-65-160	5.5	440	260	325	500	365	800	150	14	97.5	961	100	80	65	135
	7.5	440	260	325	500	365	800	150	14	97.5	961	100	80	65	138
	11	440	260	380	600	420	950	175	18	121	1097	100	80	65	195
	15	440	260	380	600	420	950	175	18	121	1097	100	80	65	205
100-65-200	18.5	505	280	380	800	420	1080	140	18	73.5	1282	100	100	65	253
	22	505	280	420	800	460	1100	150	18	81.5	1319	100	100	65	289
	30	525	300	460	800	500	1180	190	18	121.5	1379	100	100	65	349
	37	525	300	460	800	500	1180	190	18	121.5	1379	100	100	65	368
100-65-250	45	590	340	510	800	550	1250	225	22	141.5	1466	125	100	65	458
	55	620	370	575	900	625	1350	225	22	141.5	1547	125	100	65	561
	75	650	400	620	800	670	1400	300	22	214	1620	125	100	65	704
100-65-315	90	680	400	620	900	670	1450	275	22	189	1700	125	100	65	781
	110	720	440	710	1000	760	1500	250	22	164	1909	125	100	65	1212
100-80-160	11	460	260	380	800	420	1080	140	18	73.5	1212	100	100	80	209
	15	460	260	380	800	420	1080	140	18	73.5	1212	100	100	80	219
	18.5	460	260	380	800	420	1080	140	18	73.5	1282	100	100	80	239
	22	480	280	420	800	460	1100	150	18	83.5	1319	100	100	80	280
125-100-200	30	600	320	455	800	495	1200	200	18	119	1412	125	125	100	380
	37	600	320	455	800	495	1200	200	18	119	1412	125	125	100	399
	45	620	340	510	800	560	1250	225	22	141.5	1466	125	125	100	463
	55	650	370	575	900	625	1350	225	22	141.5	1547	125	125	100	566
	75	680	400	620	800	670	1400	300	22	214	1620	125	125	100	709

续表

2 极

型号	功率 (kW)	H1	H2	HC1	HC2	BW	BL	BP	BH	OH	UL	FC	DN1	DN2	总重量 (kg)
125-100-250	75	680	400	620	800	670	1400	300	22	214	1665	140	125	100	752
	90	680	400	620	900	670	1450	275	22	189	1715	140	125	100	789
	110	720	440	710	1000	760	1500	250	22	164	1924	140	125	100	1220
	90	715	400	620	900	670	1450	275	22	189	1715	140	125	100	795
125-100-315	110	755	440	710	1000	760	1500	250	22	164	1909	140	125	100	1221
	132	755	440	710	1000	760	1560	280	22	194	2034	140	125	100	1281
	160	755	440	710	1000	760	1560	280	22	194	2034	140	125	100	1401

NISO泵组外形尺寸表

4 极

型号	功率 (kW)	H1	H2	HC1	HC2	BW	BL	BP	BH	OH	UL	FC	DN1	DN2	总重量 (kg)
50-32-160	0.55	392	232	296	500	336	700	100	14	47.5	755	80	50	32	63
	0.75	392	232	296	500	336	700	100	14	47.5	755	80	50	32	64
50-32-200	1.1	440	260	296	500	336	750	125	14	72.5	794	80	50	32	90
	1.5	440	260	296	500	336	750	125	14	72.5	819	80	50	32	97
65-40-200	1.1	440	260	325	500	365	750	125	14	72.5	824	100	65	40	92
	1.5	440	260	325	500	365	750	125	14	72.5	849	100	65	40	99
	2.2	440	260	325	500	365	750	125	14	72.5	887	100	65	40	110
65-40-250	3	505	280	376	600	416	920	160	14	95	992	100	65	40	140
65-40-315	4	550	300	405	600	445	900	150	14	85	1045	125	65	40	160
	5.5	550	300	405	600	445	950	175	14	110	1101	125	65	40	182
65-50-160	0.55	392	232	296	500	336	700	100	14	47.5	755	80	65	50	65
	0.75	392	232	296	500	336	700	100	14	47.5	755	80	65	50	66
	1.1	392	232	296	500	336	700	100	14	47.5	794	80	65	50	82
80-50-200	1.5	460	260	325	500	365	750	125	14	72.5	849	100	80	50	103
	2.2	460	260	325	500	365	750	125	14	72.5	877	100	80	50	114
	3	460	260	325	500	365	750	125	14	72.5	877	100	80	50	119
80-50-250	4	505	280	376	600	416	920	160	14	95	1042	125	80	50	148
	5.5	505	280	376	600	416	920	160	14	95	1107	125	80	50	169
80-50-315	5.5	605	325	405	600	445	950	175	18	108.5	1101	125	80	50	186
	7.5	605	325	405	600	445	950	175	18	108.5	1141	125	80	50	200
80-65-160	0.75	440	260	325	500	365	700	100	14	47.5	775	100	80	65	87
	1.1	440	260	325	500	365	750	125	14	72.5	824	100	80	65	90
	1.5	440	260	325	500	365	750	125	14	72.5	849	100	80	65	97

续表

4极

型号	功率(kW)	H1	H2	HC1	HC2	BW	BL	BP	BH	OH	UL	FC	DN1	DN2	总重量(kg)
100-65-200	3	505	280	376	600	416	920	160	14	95	992	100	100	65	140
	4	505	280	376	600	416	920	160	14	95	1017	100	100	65	146
	5.5	505	280	376	600	416	920	160	14	95	1082	100	100	65	167
100-65-250	5.5	550	300	420	600	460	980	190	14	110	1111	125	100	65	179
	7.5	550	300	420	600	460	980	190	18	110	1151	125	100	65	198
100-65-315	11	605	325	460	800	500	1120	160	18	80	1267	125	100	65	299
	15	605	325	460	800	500	1120	160	18	80	1307	125	100	65	321
100-80-160	1.5	460	260	340	600	380	860	130	14	65	954	100	100	80	123
	2.2	460	260	340	600	380	860	130	14	65	982	100	100	80	119
	3	460	260	340	600	380	860	130	14	65	982	100	100	80	124
125-80-400	15	735	380	500	800	540	1150	175	18	94	1317	125	125	80	385
	18.5	735	380	500	800	540	1150	175	18	94	1374	125	125	80	420
	22	735	380	510	800	560	1220	210	22	126.5	1404	125	125	80	442
	30	735	380	510	800	560	1220	210	22	126.5	1442	125	125	80	491
125-100-200	4	580	300	420	600	460	900	150	14	70	1045	125	125	100	167
	5.5	580	300	420	600	460	980	190	18	110	1111	125	125	100	184
	7.5	580	300	420	600	460	980	190	18	110	1151	125	125	100	203
	11	580	300	420	800	460	1100	150	18	70	1237	125	125	100	254
125-100-250	15	605	325	460	800	500	1120	160	18	80	1322	140	125	100	329
125-100-315	11	665	350	460	800	500	1120	160	18	79	1282	140	125	100	312
	18.5	665	350	460	800	500	1180	190	18	109	1379	140	125	100	368
	22	665	350	460	800	500	1180	190	18	109	1409	140	125	100	385
	30	665	350	510	800	560	1220	210	22	126.5	1457	140	125	100	445
125-100-400	30	735	380	570	800	620	1220	210	22	110	1447	140	125	100	495
	37	755	400	575	900	625	1300	200	22	100	1496	140	125	100	574
	45	755	400	575	900	625	1300	200	22	100	1531	140	125	100	603
150-125-250	11	705	350	460	800	500	1120	160	18	79	1282	140	150	125	308
	15	705	350	460	800	500	1120	160	18	79	1322	140	150	125	335
	18.5	705	350	460	800	500	1180	190	18	109	1379	140	150	125	366
	22	705	350	460	800	500	1180	190	18	109	1409	140	150	125	383

续表

4极

型号	功率(kW)	H1	H2	HC1	HC2	BW	BL	BP	BH	OH	UL	FC	DN1	DN2	总重量(kg)
150-125-315	30	735	380	570	800	620	1220	210	22	110	1447	140	150	125	481
	37	755	400	575	900	625	1300	200	22	100	1496	140	150	125	558
150-125-400	45	835	435	575	900	625	1300	200	22	100	1531	140	150	125	612
	55	835	435	575	900	625	1350	225	22	125	1592	140	150	125	670
	75	835	435	620	800	670	1400	300	22	200	1665	140	150	125	827
200-150-315	37	835	435	620	800	670	1400	300	22	200	1656	160	200	150	613
	45	835	435	595	900	645	1500	300	22	200	1691	160	200	150	651
	55	835	435	595	900	645	1500	300	22	200	1752	160	200	150	723
200-150-400	75	835	435	625	1000	675	1600	300	22	200	1835	160	200	150	879
	75	885	435	625	1000	675	1600	300	22	200	1835	160	200	150	932
	90	885	435	625	1000	675	1600	300	22	200	1885	160	200	150	1028
250-200-315	110	885	435	710	1200	760	1700	250	22	150	2124	160	200	150	1398
	37	885	435	620	800	670	1400	300	22	200	1676	180	250	200	664
	45	885	435	595	900	645	1500	300	22	200	1711	180	250	200	702
250-200-400	55	885	435	595	900	645	1500	300	22	200	1772	180	250	200	768
	75	885	435	625	1000	675	1600	300	22	200	1855	180	250	200	913
	90	950	500	625	1000	675	1600	300	22	200	1905	180	250	200	1087
250-200-400	110	950	500	710	1200	760	1700	250	22	150	2144	180	250	200	1473
	132	950	500	710	1200	760	1750	275	22	175	2244	180	250	200	1568
	160	950	500	710	1200	760	1750	275	22	175	2244	180	250	200	1637

NIS, NISF泵外形尺寸图

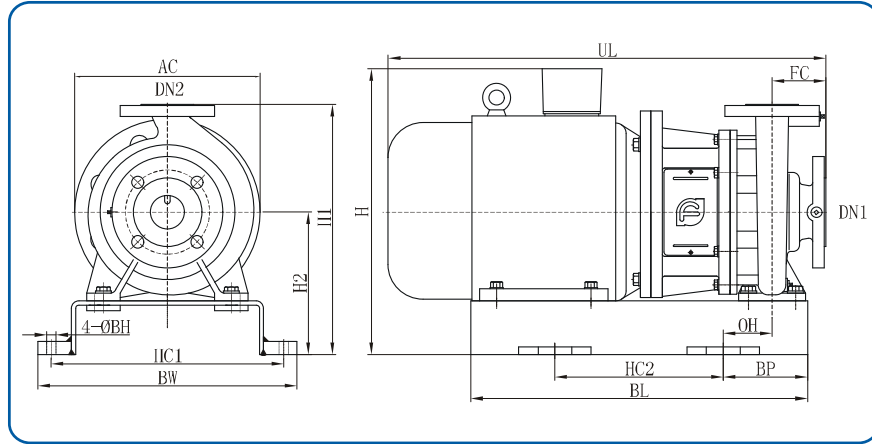

NIS, NISF泵外形尺寸表

2极

型号	功率 (kW)	H	H1	H2	HC1	HC2	BW	BL	BP	BH	OH	UL	FC	DN1	DN2	总重量 (kg)
50-32-160	3	382	372	212	306	250	336	450	100	14	47.5	563	80	50	32	75
	4	400	372	212	306	250	336	450	100	14	47.5	578	80	50	32	81
	5.5	425	372	212	335	300	365	500	100	14	47.5	650	80	50	32	105
50-32-200	7.5	453	420	240	350	300	380	500	100	14	46	650	80	50	32	120
	11	500	420	240	390	350	420	600	125	18	71	787	80	50	32	175
65-40-200	7.5	453	420	240	335	300	365	500	100	14	47.5	670	100	65	40	120
	11	500	420	240	390	350	420	600	125	18	71	807	100	65	40	177
	15	500	420	240	390	350	420	600	125	18	71	807	100	65	40	187
65-40-250	18.5	520	485	260	390	400	420	660	130	18	63.5	865	100	65	40	222
	22	535	485	260	430	400	460	700	150	18	81.5	895	100	65	40	257
	30	585	505	280	470	450	500	750	150	18	81.5	967	100	65	40	318
65-40-315	22	555	530	280	430	400	460	700	150	18	81.5	920	125	65	40	270
	30	585	530	280	465	500	495	800	150	18	81.5	992	125	65	40	340
	37	585	530	280	465	500	495	800	150	18	81.5	992	125	65	40	359
	45	640	555	305	520	500	560	820	160	22	90	1042	125	65	40	428
65-50-160	4	400	372	212	306	250	336	450	100	14	47.5	578	80	65	50	83
	5.5	425	372	212	335	300	365	500	100	14	47.5	650	80	65	50	107
	7.5	425	372	212	335	300	365	500	100	14	47.5	650	80	65	50	110

续表

2极

型号	功率 (kW)	H	H1	H2	HC1	HC2	BW	BL	BP	BH	OH	UL	FC	DN1	DN2	总重量 (kg)
80-50-200	11	500	440	240	390	350	420	600	125	18	71	807	100	80	50	181
	15	500	440	240	390	350	420	600	125	18	71	807	100	80	50	191
	18.5	500	440	240	390	400	420	660	130	18	76	862	100	80	50	211
	22	535	460	260	430	400	460	700	150	18	96	892	100	80	50	254
80-50-250	30	585	505	280	470	450	500	750	150	18	81.5	992	125	80	50	320
	37	585	505	280	470	450	500	750	150	18	81.5	992	125	80	50	339
80-50-315	37	610	585	305	465	500	495	800	150	18	81.5	992	125	80	50	370
	45	640	585	305	520	500	560	820	160	22	90	1042	125	80	50	434
	55	715	630	350	585	550	625	950	200	22	130	1156	125	80	50	534
	75	780	660	380	630	600	670	1000	200	22	130	1231	125	80	50	675
80-65-160	5.5	453	420	240	335	300	365	500	100	14	47.5	670	100	80	65	115
	7.5	453	420	240	335	300	365	500	100	14	47.5	670	100	80	65	118
	11	500	420	240	390	350	420	600	125	18	71	807	100	80	65	175
	15	500	420	240	390	350	420	600	125	18	71	807	100	80	65	185
100-65-200	18.5	520	485	260	390	400	420	660	130	18	63.5	865	100	100	65	222
	22	535	485	260	430	400	460	700	150	18	81.5	895	100	100	65	257
	30	585	505	280	470	450	500	750	150	18	81.5	967	100	100	65	318
	37	585	505	280	470	450	500	750	150	18	81.5	967	100	100	65	337
100-65-250	45	640	555	305	520	500	560	820	160	22	76.5	1042	125	100	65	426
	55	715	600	350	585	550	625	950	200	22	116.5	1156	125	100	65	529
	75	780	630	380	630	600	670	1000	200	22	114	1231	125	100	65	673
100-65-315	90	780	660	380	630	600	670	1100	250	22	164	1295	125	100	65	730
	110	945	695	415	720	600	760	1100	250	22	164	1530	125	100	65	1161
	11	500	440	240	390	400	420	660	130	18	63.5	810	100	100	80	177
100-80-160	15	500	440	240	390	400	420	660	130	18	63.5	810	100	100	80	187
	18.5	500	440	240	390	400	420	660	130	18	63.5	865	100	100	80	207
	22	535	460	260	430	400	460	700	150	18	83.5	895	100	100	80	248
	30	585	560	280	465	500	495	800	150	18	69	992	125	125	100	349
125-100-200	37	585	560	280	465	500	495	800	150	18	69	992	125	125	100	368
	45	640	585	305	520	500	560	820	160	22	76.5	1042	125	125	100	431
	55	715	630	350	585	550	625	950	200	22	116.5	1156	125	125	100	534
	75	780	660	380	630	600	670	1000	200	22	114	1231	125	125	100	678

续表

2 极

型号	功率 (kW)	H	H1	H2	HC1	HC2	BW	BL	BP	BH	OH	UL	FC	DN1	DN2	总重量 (kg)
125-100-250	75	780	660	380	630	600	670	1000	200	22	114	1265	140	125	100	701
	90	780	660	380	630	600	670	1100	250	22	164	1315	140	125	100	738
	110	945	695	415	720	600	760	1100	250	22	164	1523	140	125	100	1169
125-100-315	90	780	695	380	630	600	670	1100	250	22	164	1310	140	125	100	744
	110	945	730	415	720	600	760	1100	250	22	164	1545	140	125	100	1170
	132	945	730	415	720	700	760	1220	260	22	174	1655	140	125	100	1230
	160	945	730	415	720	700	760	1220	260	22	174	1655	140	125	100	1350

NIS, NISF泵外形尺寸表

4 极

型号	功率 (kW)	H	H1	H2	HC1	HC2	BW	BL	BP	BH	OH	UL	FC	DN1	DN2	总重量 (kg)
50-32-160	0.55	352	372	212	306	250	336	400	75	14	22.5	483	80	50	32	44
	0.75	352	372	212	306	250	336	400	75	14	22.5	483	80	50	32	45
50-32-200	1.1	400	420	240	306	250	336	400	75	14	22.5	498	80	50	32	71
	1.5	400	420	240	306	250	336	400	75	14	22.5	523	80	50	32	78
65-40-200	1.1	400	420	240	335	250	365	400	75	14	22.5	518	100	65	40	73
	1.5	400	420	240	335	250	365	400	75	14	22.5	543	100	65	40	80
	2.2	410	420	240	335	250	365	450	100	14	47.5	583	100	65	40	91
65-40-250	3	430	485	260	386	300	416	500	100	14	35	591	100	65	40	109
65-40-315	4	468	530	280	415	300	445	500	100	14	35	631	125	65	40	128
	5.5	493	530	280	415	300	445	500	100	14	35	687	125	65	40	151
65-50-160	0.55	352	372	212	306	250	336	400	75	14	22.5	483	80	65	50	46
	0.75	352	372	212	306	250	336	400	75	14	22.5	483	80	65	50	47
	1.1	372	372	212	306	250	336	400	75	14	22.5	498	80	65	50	63
80-50-200	1.5	400	440	240	335	250	365	400	75	14	22.5	543	100	80	50	84
	2.2	410	440	240	335	250	365	450	100	14	47.5	583	100	80	50	95
	3	410	440	240	335	250	365	450	100	14	47.5	583	100	80	50	100
80-50-250	4	448	485	260	386	300	416	500	100	14	35	631	125	80	50	116
	5.5	473	485	260	386	300	416	500	100	14	35	687	125	80	50	137
80-50-315	5.5	518	585	305	415	350	445	550	100	18	33.5	687	125	80	50	155
	7.5	518	585	305	415	350	445	550	100	18	33.5	727	125	80	50	169
80-65-160	0.75	380	420	240	335	250	365	400	75	14	22.5	503	100	80	65	67
	1.1	400	420	240	335	250	365	400	75	14	22.5	518	100	80	65	71
	1.5	400	420	240	335	250	365	400	75	14	22.5	543	100	80	65	78

续表

4 极

型号	功率 (kW)	H	H1	H2	HC1	HC2	BW	BL	BP	BH	OH	UL	FC	DN1	DN2	总重量 (kg)
100-65-200	3	430	485	260	386	300	416	500	100	14	35	591	100	100	65	109
	4	448	485	260	386	300	416	500	100	14	35	606	100	100	65	114
	5.5	473	485	260	386	300	416	500	100	14	35	662	100	100	65	135
100-65-250	5.5	493	530	280	430	350	460	550	100	14	20	687	125	100	65	147
	7.5	493	530	280	430	350	460	550	100	18	20	727	125	100	65	166
100-65-315	11	565	585	305	470	400	500	700	150	18	70	854	125	100	65	249
	15	565	585	305	470	400	500	700	150	18	70	909	125	100	65	270
100-80-160	1.5	400	440	240	350	200	380	410	105	14	40	536	100	100	80	91
	2.2	410	440	240	350	300	380	500	100	14	35	591	100	100	80	87
	3	410	440	240	350	300	380	500	100	14	35	591	100	100	80	92
125-80-400	15	620	715	360	510	450	540	750	150	18	68	911	125	125	80	334
	18.5	635	715	360	510	450	540	750	150	18	68	941	125	125	80	369
	22	635	715	360	520	450	560	750	150	22	66.5	981	125	125	80	391
	30	665	715	360	520	500	560	820	160	22	76.5	1015	125	125	80	440
	37	695	715	360	520	500	560	820	160	22	76.5	1058	125	125	80	498
125-100-200	4	468	560	280	430	300	460	500	100	14	20	631	125	125	100	136
	5.5	493	560	280	430	350	460	550	100	18	20	687	125	125	100	152
	7.5	493	560	280	430	350	460	550	100	18	20	727	125	125	100	171
125-100-250	11	540	560	280	430	400	460	650	125	18	45	835	125	125	100	222
	15	565	585	305	470	400	500	700	150	18	70	924	140	125	100	278
125-100-315	11	590	645	330	470	400	500	700	150	18	69	869	140	125	100	261
	18.5	605	645	330	470	450	500	750	150	18	69	954	140	125	100	317
	22	605	645	330	470	450	500	750	150	18	69	994	140	125	100	335
125-100-400	30	635	645	330	520	500	560	820	160	22	76.5	1028	140	125	100	394
	30	665	715	360	580	500	620	800	150	22	50	1028	140	125	100	444
	37	715	735	380	585	550	625	950	200	22	100	1071	140	125	100	523
150-125-250	45	715	735	380	585	550	625	950	200	22	100	1101	140	125	100	552
	11	590	685	330	470	400	500	700	150	18	69	869	140	150	125	257
150-125-250	15	590	685	330	470	400	500	700	150	18	69	924	140	150	125	284
	18.5	605	685	330	470	450	500	750	150	18	69	954	140	150	125	315
	22	605	685	330	470	450	500	750	150	18	69	994	140	150	125	333

续表

4极

型号	功率 (kW)	H	H1	H2	HC1	HC2	BW	BL	BP	BH	OH	UL	FC	DN1	DN2	总重量 (kg)
150-125-315	30	665	715	360	580	500	620	800	150	22	50	1028	140	150	125	430
	37	715	735	380	585	550	625	950	200	22	100	1071	140	150	125	507
150-125-400	45	750	815	415	585	550	625	950	200	22	100	1103	140	150	125	561
	55	780	815	415	585	550	625	950	200	22	100	1187	140	150	125	620
	75	815	815	415	630	600	670	1000	200	22	100	1262	140	150	125	776
200-150-315	37	750	815	415	605	500	670	900	200	22	100	1116	160	200	150	541
	45	750	815	415	605	500	645	900	200	22	100	1146	160	200	150	579
	55	780	815	415	605	600	645	1000	200	22	100	1254	160	200	150	650
	75	815	815	415	630	600	675	1100	250	22	150	1329	160	200	150	806
200-150-400	75	815	865	415	630	600	675	1100	250	22	150	1329	160	200	150	859
	90	815	865	415	630	600	675	1100	250	22	150	1379	160	200	150	956
	110	945	865	415	720	700	760	1220	260	22	160	1614	160	200	150	1325
250-200-315	37	750	865	415	605	500	670	900	200	22	100	1136	180	250	200	592
	45	750	865	415	605	500	645	900	200	22	100	1166	180	250	200	630
	55	780	865	415	605	600	645	1100	250	22	150	1274	180	250	200	695
	75	815	865	415	630	600	675	1100	250	22	150	1349	180	250	200	840
250-200-400	90	845	930	480	630	600	675	1100	250	22	150	1399	180	250	200	1015
	110	1010	930	480	720	750	760	1250	250	22	150	1634	180	250	200	1400
	132	1010	930	480	720	700	760	1220	260	22	160	1744	180	250	200	1495
	160	1010	930	480	720	700	760	1220	260	22	160	1744	180	250	200	1564

NIS, NISF 法兰

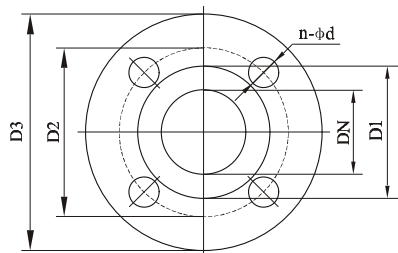

DN	D1	D2	D3	n	d
32	78	100	140	4	18
50	102	125	165	4	18
65	122	145	185	4	18
80	133	160	200	8	18
100	158	180	220	8	18
125	184	210	250	8	18
150	212	240	285	8	22
200	268	295	340	12	22
250	320	355	405	12	26